

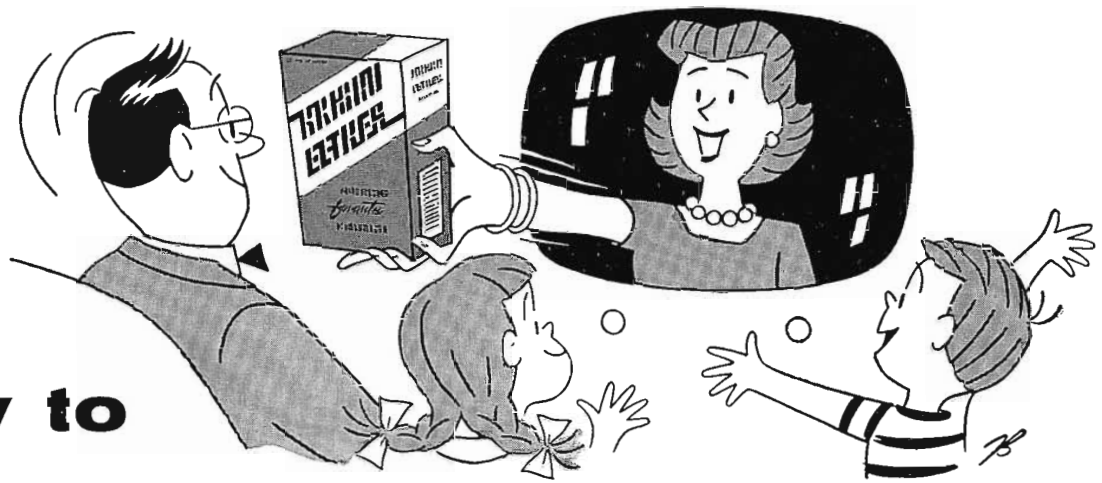

BROADCAST NEWS

VOL. NO. 85 OCTOBER, 1955





How to make your film programs produce "LIVE" picture interest

WHEN your film programs have the "snap" and realism characteristic of "live" pick-ups, you have a client benefit that sells itself and pays off handsomely. If you can achieve picture quality which will make it difficult for a television viewer to know whether the program coming into his home is "live" or "on film," you're in business!

It's possible to do just this with good black and white films—simply by replacing outmoded equipment.

Studio realism— highest picture quality

RCA's TK-21 Vidicon Film Camera is the answer. This improved equipment offers all the dimension associated with "live" programs, provides studio realism and highest picture quality. It's so life-like, the viewer gets the impression that the show is being presented in the studio just for him! Thus, the spot advertiser is offered the psychological advantage of "live" programming at the low cost of film. Competitively, this is your bread-and-butter business and its growth will be measured in direct proportion to its effectiveness.

A check of some of the more technical advantages shows why the TK-21 Film Camera is a station's best investment for extra profits . . .

"Live" picture sharpness

The TK-21 is the only film system with enough signal output to use aperture correction to bring picture detail up to maximum sharpness (detail resolution 100% at 350 lines) with a high signal to noise ratio.

"Live" picture contrast

The Vidicon tube is ideal for film reproduction. It has unexcelled contrast range

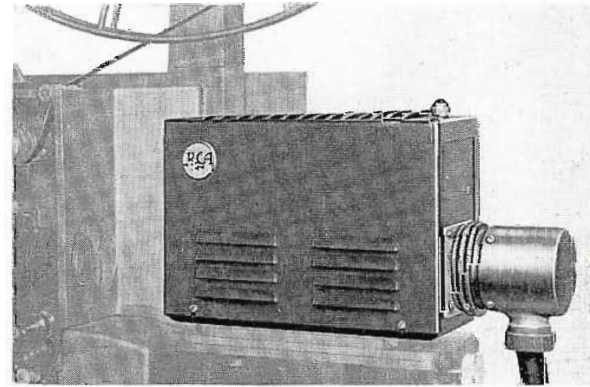

and assures realistic gray scale rendition over entire picture. This means you can get studio realism in your film pictures.

Edge-lighting, shading eliminated

The RCA Vidicon operates entirely without edge-lighting, electrical shading, or any other form of supplemental lighting. This camera virtually runs by itself. Used for finest quality reproduction of monochrome motion picture films or slides in a television system, the TK-21 may be mounted directly to projectors or multiplexed.

For complete information about the TK-21 Vidicon Film Camera, call your RCA Broadcast Sales Representative.

Ask
the Engineer
—he knows



**RADIO CORPORATION
of AMERICA**

ENGINEERING PRODUCTS DIVISION • CAMDEN, N.J.

In Canada: RCA VICTOR Company Limited, Montreal

Vol. No. 85

October, 1955

BROADCAST NEWS

published by

RADIO CORPORATION OF AMERICA
ENGINEERING PRODUCTS DIVISION CAMDEN, NEW JERSEY

PRICE *In continental U.S.A. --- \$4.00 for 12 issues*
 In other countries ----- \$5.00 for 12 issues

CONTENTS

THE STORY OF HILL TOWER AND THE RCA "CANDELABRA"	8
DEVELOPMENT OF THE "CANDELABRA" ANTENNA SYSTEM <i>by L. J. Wolf</i>	12
CONSTRUCTION AND ERECTION OF THE "CANDELABRA" ANTENNA SYSTEM	18
WLDB—ATLANTIC CITY'S NEWEST RADIO VOICE REMOTE CONTROLLED	26
BROADCAST AND COMMUNICATIONS EQUIPMENT WITHSTANDS ATOM BLAST <i>by E. C. Bill</i>	30
RCA DEMONSTRATES COLOR TV FOR MEDICAL USE <i>by E. T. Griffith</i>	38
RCA COLOR TELEVISION TO BE USED AT WALTER REED MEDICAL CENTER	43
KROC-TV SHOWS HOW TO ACHIEVE EFFICIENT, LOW-COST OPERATION . . . <i>by Robert Cross and Kenneth Stollenberg</i>	44
CONTROL OF LIGHT INTENSITY IN TELEVISION PROJECTORS <i>by K. Sadashige and B. F. Melchionni</i>	52
35MM INTERMITTENT MOTION PICTURE PROJECTOR FOR COLOR TV <i>by W. R. Isom and W. F. Fisher</i>	58
TELEVISIONING OPAQUES AT WMUR-TV <i>by Charles F. Halle</i>	64

"RCA PIONEERED AND DEVELOPED COMPATIBLE COLOR TELEVISION"

Copyright 1955, Radio Corporation of America, Engineering Products Division, Camden, N. J.

PRINTED
IN
U.S.A.

TK-21

VIDICON

RCA's Superior



**For
MULTIPLEXING,
or direct use!**

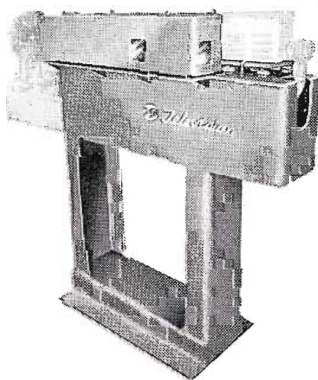

RCA's TK-21 Vidicon Film Camera can be used with RCA's Multiplexer, TP-11, for multiple picture inputs (see illustration opposite page). Or, it can be mounted directly on any of the RCA TV Projectors—such as the TP-16, TP-35, or TP-6A (see above).

film-camera

film camera chain

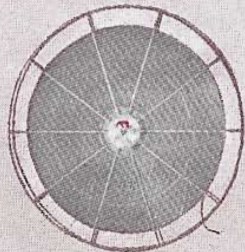

DEVELOPED HAND IN HAND with the new RCA-6326 VIDICON tube, RCA's TK-21 Film Camera does for *film* picture quality what the RCA Image Orthicon Camera has done for "live" picture quality.

"Live" picture sharpness!

For unsurpassed picture detail, choose the RCA Vidicon film camera! It's the only film pick-up system with enough signal output (and low enough noise in the signal) to use *aperture response correction*. Aperture response correction brings picture detail to maximum sharpness (detail resolution, 100% at 350 lines) while holding a high signal-to-noise ratio. *Benefit:* You produce finer film pictures . . . with a quality you get from your studio camera.

"Live" picture contrast!

The RCA Vidicon adds "studio" realism to your film pictures. The gamma characteristic of the Vidicon tube is ideal for film reproduction . . . 0.65, constant over a dynamic range of 150 to 1. *Benefit:* You get more realistic film pictures than ever before possible.

Low light source requirements!

The high light sensitivity of the RCA VIDICON film camera enables you to reduce projection lamp voltage, reduce heating, increase lamp life substantially.

Edge-lighting, shading eliminated!

The RCA VIDICON operates entirely without edge-lighting, electrical shading, and any other form of supplemental lighting. *Benefit:* You adjust "wall focus" and "beam" from day to day . . . then this camera virtually runs by itself.

RCA VIDICON Film-Camera Chain TK-21 includes:

- | | |
|------------------------------------|--|
| 1 VIDICON Camera MI-26021 | 1 TM-6B Master Monitor MI-26136-A |
| 1 RCA-6326 VIDICON Tube MI-26671 | 1 Master Monitor Kinescope MI-26655 |
| 1 Control Chassis MI-26061 | 1 Master Monitor C-R Tube MI-26665 |
| 1 Deflection Chassis MI-26081 | 1 Blower MI-26579-B |
| 1 Remote Control Panel MI-26241 | 1 Console Housing MI-26266-B |
| 2 WP-33B Power Supplies MI-26085-B | 1 Camera Cable & Connectors MI-26725-A10 |

For the finest TV film reproduction you've ever seen, specify an RCA VIDICON film-camera system. Ask your RCA Broadcast Sales Representative for technical details. In Canada, write RCA-Victor Ltd., Montreal.

RCA PIONEERED AND DEVELOPED COMPATIBLE COLOR TELEVISION



RADIO CORPORATION of AMERICA
ENGINEERING PRODUCTS DIVISION
CAMDEN, N.J.

4 picture sources in multiplexed use!

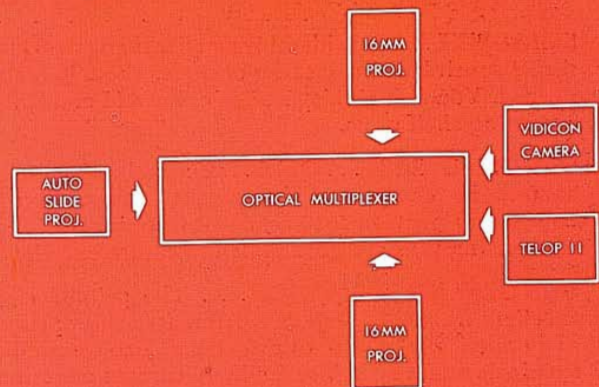
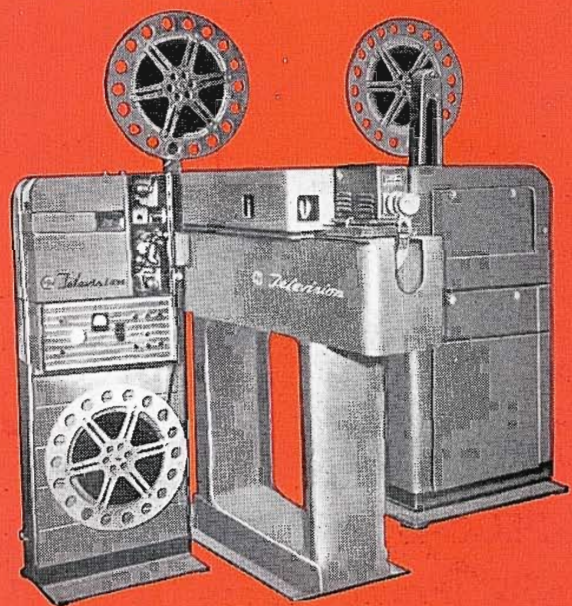

An RCA Multiplexer, Type TP-II allows a single Vidicon Camera to accept up to four film picture sources—two 16mm or 35mm film projectors, a TP-3B, 35mm automatic slide projector, and a Telop II slide and opaque projector. The multiplexer is pictured above in a multi-input film system using two RCA TP-6A professional film projectors.



NOW...

RCA PRINTED CIRCUIT

PLUG-IN AMPLIFIERS FOR BROADCAST USE!

Provide These Outstanding Benefits...

SMALL SIZE . . . Considerably smaller than previous Broadcast Audio Amplifiers the RCA printed circuit series occupies about $\frac{1}{2}$ the rack and shelf space formerly needed. You free rack space for other AM and TV equipment, reduce rack and mounting shelf costs.

HANDLING EASE . . . Quick, safe and effortless installation or removal is assured by compact, light weight construction. Dependable 15-pin keyed connectors provide fool-proof positioning for rapid "in and out" handling. Connecting pins are gold plated to assure excellent electrical contact.

UNIFORM PERFORMANCE . . . The printed circuit assures uniformity and excellent frequency response. All units achieve extra dependability through use of hermetically sealed transformers. Each amplifier is provided with output terminals and a switch to facilitate current metering.

REDUCED-SIZE ACCESSORIES . . . Accessories such as BR-22A mounting shelf and BX-21A power supply used with the printed circuit amplifiers have also been "miniaturized." Example: shelf BR-22A, only $5\frac{1}{4}$ " high can accommodate the following combinations of equipment: 10 BA-21A Preamplifiers, 3 BA-23A Program Amplifiers plus 1 BA-21A, 2 BX-21A Power Supplies plus 2 BA-21A, 2 BA-24A Monitor Amplifiers.

For complete details of the many further advantages of RCA's printed circuit amplifiers, call your nearest RCA Broadcast Representative. Ask for literature.



RADIO CORPORATION of AMERICA
ENGINEERING PRODUCTS DIVISION
CAMDEN, N.J.

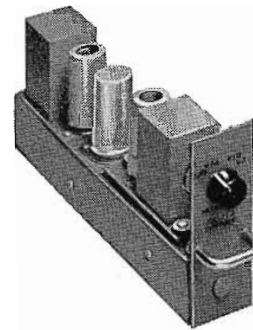

BA-21A PREAMPLIFIER . . . Ideal as a microphone preamplifier, turntable preamplifier or booster amplifier. May be used as isolation amplifier by adding an MI-11278-E or F bridging volume control. Due to its small size, it may be placed in a control console, control desk or transcription turntable cabinet. One to ten of these units may be installed in a single BR-22A panel and shelf assembly.

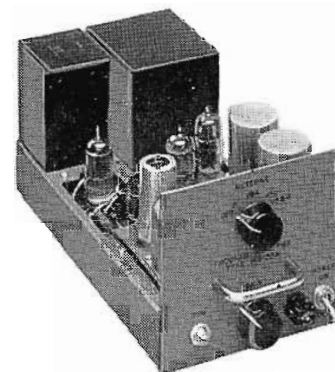

BA-23A PROGRAM AMPLIFIER . . . A versatile high-fidelity amplifier using special high-quality components and providing maximum accessibility. High gain and low distortion make it without equal as (1) program or line amplifier, (2) bridging amplifier, (3) isolation amplifier. Three BA-23A amplifiers can be mounted on BR-22A shelf with space for an additional amplifier.

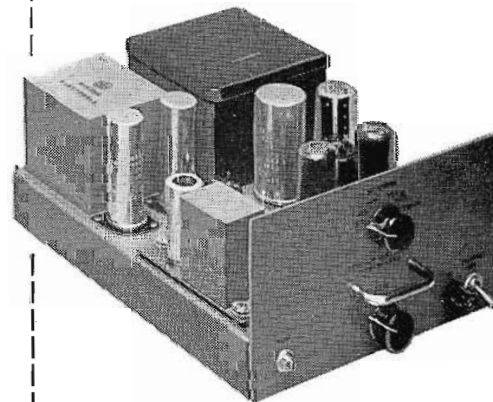

BA-24A MONITORING AMPLIFIER . . . A high fidelity, high-gain, flexible 8-watt amplifier suitable for monitoring, audition, recording and talk-back uses. Also serves as a program or line amplifier. Excellent for transcription playback booths, since the 105 db gain will operate a speaker (LC-1A) directly from the output of a turntable (70-series). Also an excellent recording amplifier.

NEW RCA TURNTABLE...

BQ-2A



Now ready for immediate delivery. The BQ-2A mechanism is also available separately as MI-11830. Call your Broadcast Sales Representative for further details.

Designed from the ground up for 3-speed operation

RCA's answer to the need for a new turntable designed specifically for 3-speed operation at moderate cost, with highest performance characteristics. Features include:

- Smoother, simpler speed changing, with snap-up spindle hub to provide improved 45 RPM operation.
- Smooth, half-turn starting at all speeds for easy cueing. Simple, sure-fire, self-compensating rim drive mechanism.
- Modern, practical 2-tone grey cabinet of ample functionalized proportions. Accommodates booster amplifiers inside, tone arms and other accessories on top of cabinet.



RADIO CORPORATION of AMERICA

ENGINEERING PRODUCTS DIVISION, CAMDEN, N. J.

In Canada: RCA VICTOR Company Limited, Montreal

RCA AMPLI

RCA *Ampliphase* RCA

**50-KW AM
AIR COOLED!**

**New RCA 50-kilowatt
AM Transmitter BTA-50G**

**DESIGNED WITH
AMPLIPHASE MODULATION**

HOW IT WORKS!

To produce phase-to-amplitude modulation in the BTA-50G, a carrier wave is developed by a common exciter. This carrier wave is then split and fed to two separate amplifier chains through phase-shift networks that establish a carrier phase difference. These two signals are controlled so that each maintains a prescribed phase relationship with the other in accordance with the intensity of modulating signal. This controlled phase relationship enables the separate 25-kilowatt amplifiers, when feeding their outputs into a combining circuit, to produce a maximum level 50-kilowatt amplitude modulated signal.

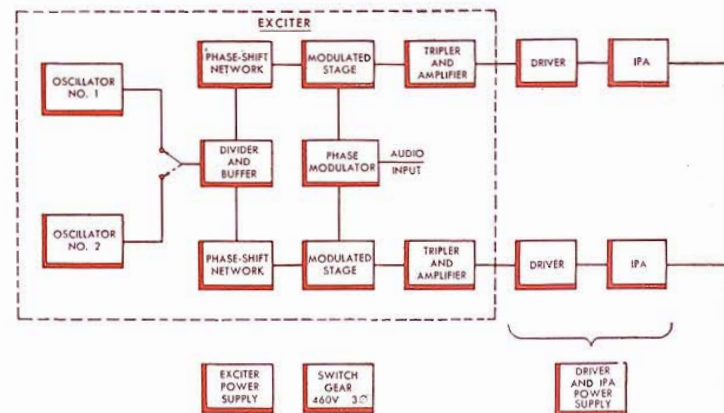

SIMPLIFIED BLOCK DIAGRAM—BTA-50G TRANSMITTER

PHASE

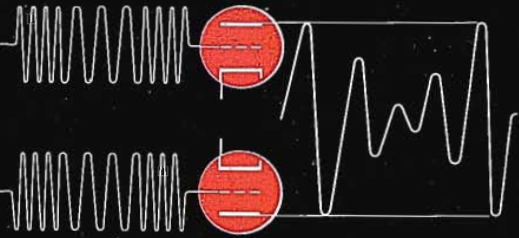

A new concept in AM Broadcasting!

... introduced in RCA's revolutionary new 50-KW AM transmitter

Here is the most significant forward step in AM transmitters since RCA introduced high level modulation—an entirely new 50-KW transmitter using Ampliphase Modulation. Newest and finest in RCA's long line of distinguished AM transmitter designs, it is further proof of RCA leadership in the broadcast equipment field.

Ampliphase cuts transmitter floor space and operating costs by substantial margins. The BTA-50G is housed in four cubicles. It does away with half of present power tubes . . . along with bulky components such as modulation transformers,

reactors and accessories. It requires no underfloor trenches, costly water cooling systems, external blowers. And there's no lost air-time—because the 50-KW Ampliphase is remarkably easy to install while your present transmitter is in operation. Then, in most cases, you may keep your old unit as a stand-by.

For complete technical details . . . and for information on the surprisingly low price . . . call your RCA Broadcast Sales Representative. In Canada, write RCA VICTOR Company Limited, Montreal.

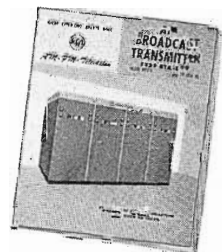

FACTS ABOUT RCA'S NEW 50-KW AM

- Takes less than 80 square feet of floor space. No underfloor trenches required.
- Lowest operating cost of any 50-KW AM transmitter.
- Half the tube cost of other 50-KW AM transmitters.
- Uses famous Long-Life RCA 5671 P.A. tubes.
- No Modulation transformer required.
- Completely air-cooled with internal blowers—no air intake ducts necessary.
- Low distortion, excellent frequency response.
- Splatter-free modulation provided by new Ampliphase design.
- Designed to permit remote-control operation.
- New simplified circuitry. Extremely stable operation.

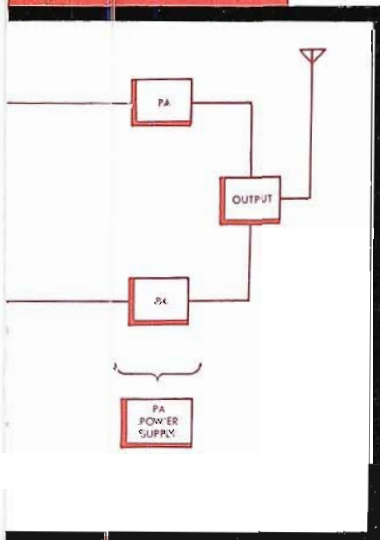

PIONEERS IN AM BROADCASTING FOR OVER 25 YEARS



RADIO CORPORATION of AMERICA
ENGINEERING PRODUCTS DIVISION

CAMDEN, N.J.



THE STORY OF HILL TOWER AND THE RCA "CANDELABRA"

The story of Hill Tower depicts the start and finish of a mammoth task . . . the task of erecting a giant "electronic skyscraper" reaching 1521 feet into Texas skies. The tower and its "Candelabra" antenna system is the most unique structure ever designed for television transmission. WFAA-TV and KRLD-TV, with antennas which radiate maximum power, are the occupants of Hill Tower.

Hill Tower stands as a tribute to those who have conceived and fulfilled this mammoth task—and a monument to engineering genius and men of many skills.

TOWER FOR TWO

*RCA Candelabra Solves Problem For Dallas Stations—
Provides Two Antennas At Equal Height On One Tower*

When Dallas' two highly-competitive TV stations—KRLD-TV and WFAA-TV—decided, almost at the same moment, to go to maximum power, move to new locations and put up new towers designed to achieve the greatest possible coverage, everyone sat back to watch the fireworks. This wasn't something simple—like Texas against the world. This was Texas against Texas—and the sky's the limit!

But the sky wasn't the limit—1521 feet was. And even in Texas 1521-foot towers are mighty expensive—mighty expensive, podner! Moreover, there was only one "best" location. So why not a single tower for both stations. Even the Hatfields and

McCoys could see the sense of that (not to mention the saving of half-a-million or so dollars in cold cash).

There was only one question. Who was to be top dog on the tower? A little extra coverage—and a whole lot of Texas pride—rode on the answer. Neither side would give an inch. Both antennas had to be at exactly the same height.

Faced with this dilemma, but not willing to give up, engineers of the two stations and their consultants huddled with engineers of RCA's antenna design group. The idea they came up with was like nothing ever seen before—not even in Texas. Dubbed "the Candelabra" it consists, es-

entially, of a tower-top platform on which the two antennas are mounted side-by-side.

Although simple in conception the candelabra idea was fraught with potential difficulties due to possible interference between antennas. Careful and exhaustive studies of this problem were made by RCA engineers, using information and experience gained in previous multiple-antenna installations made by RCA. Not until they were sure the candelabra would work was it decided to go ahead. Then Hill Tower, Inc.—a corporation formed jointly, and owned equally by the two stations, placed an order with RCA for the complete installation of tower and two antennas—approximately a million dollar job.

Representatives of The Dallas Morning News and The Dallas Times Herald on hand to witness first steel section being placed. Left to right: John W. Runyon, Pres of The Dallas Times Herald; James Moroney, Jr., Treas. of The News; W. A. Greenwell, Exec. Vice-Pres. of The Times Herald; Joe Lubben, Vice-Pres. of The News.

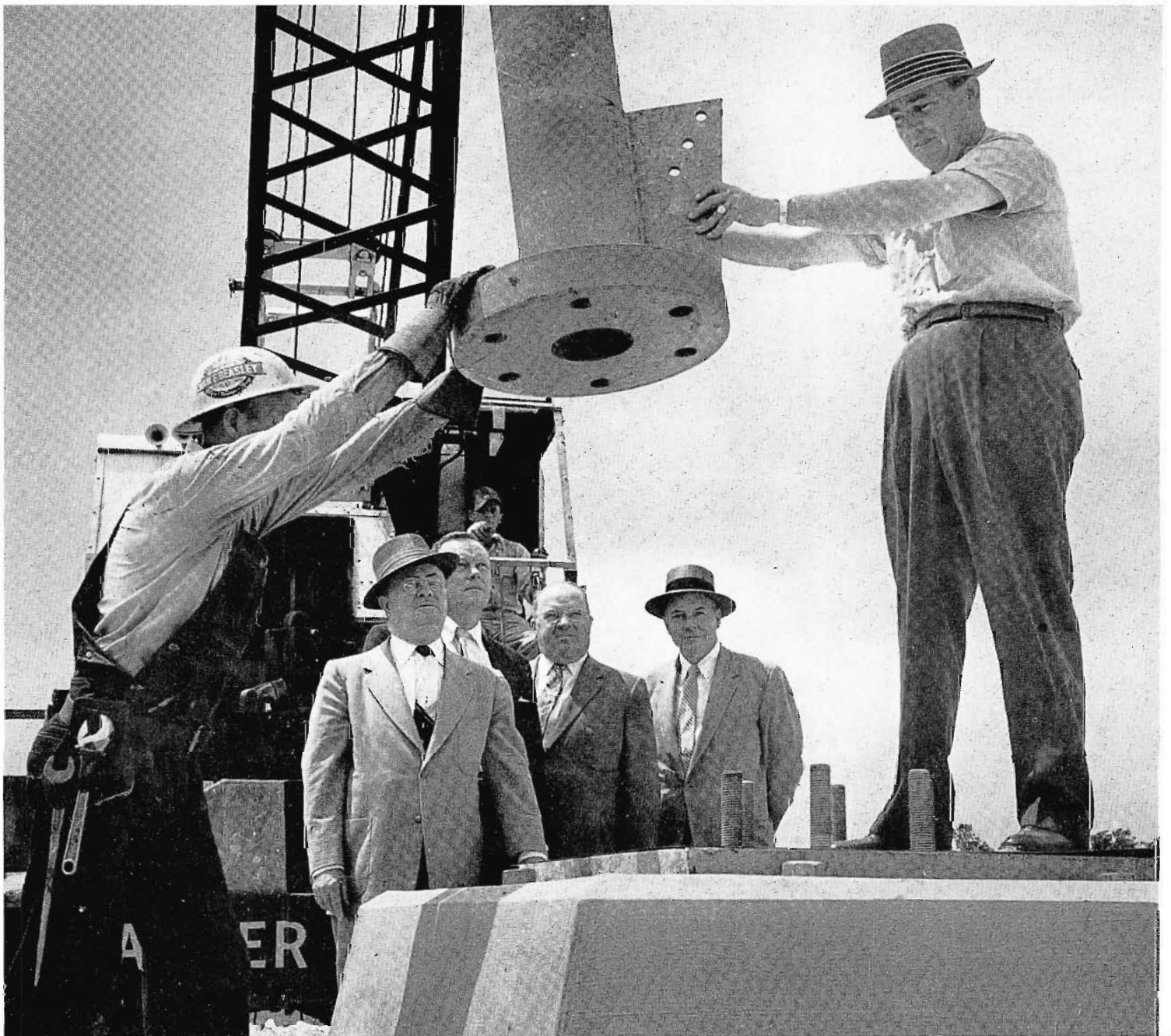

TOWER FOR TWO

Hill Tower, owned and operated by Hill Tower, Incorporated, is the world's most unique tall-tower installation . . . unique both from the standpoint of engineering design and the fact that two stations—KRLD-TV and WFAA-TV occupy the same tower with antennas of equal height and equal centers of radiation.

Unlike other tall towers, this 1521-foot "electronic skyscraper" is topped with a huge 80-foot triangular platform. The main tower structure is a guyed, triangular, uniform-cross-section type, 12 feet on a face.

A triangular platform was decided upon from a design standpoint because of its inherent structural dependability and its relative symmetry to the main tower structure. The 80-foot platform bears two RCA high-power, high-gain superturnstile antennas in "Candelabra" fashion. Each antenna in conjunction with its transmitter provides maximum E.R.P. The antennas are mounted on two of the corners—the third corner, unoccupied at present, is counter-balanced by built-in structural members.

TOWER DESIGNED BY DRESSER-IDECO

The tower was designed and fabricated by the Dresser-Ideco Company of Columbus, Ohio. Construction began on May 2, 1955 and was completed late October, 1955. Overall cost of the project was approximately one million dollars. The Ideco estimate for two separate towers to do a similar job was approximately 50% more than the present twin arrangement on the single tower. The twin antenna system also simplified air space clearance problems. The location of the tower is at Cedar Hill, Texas—about 18 miles southwest of Dallas.

MEASUREMENTS "TO-THE-INCH"

Overall height including antenna—
1520' 9".

Height to base of antenna—1435' 0".

ANTENNAS

KRLD-TV, RCA TF-6BM Channel 4 antenna, weight 10,000 pounds, height 82' 9", six batwing sections.

WFAA-TV, RCA TF-12AH Channel 8 antenna, 12 batwing sections, weight 8,000 pounds, height 72' 11" (to which ten feet was added to make beacon levels of both antennas the same).

Total tower weight is 1,420,000 pounds or 710 tons exclusive of guys, lighting, antennas, transmission lines and accessories.

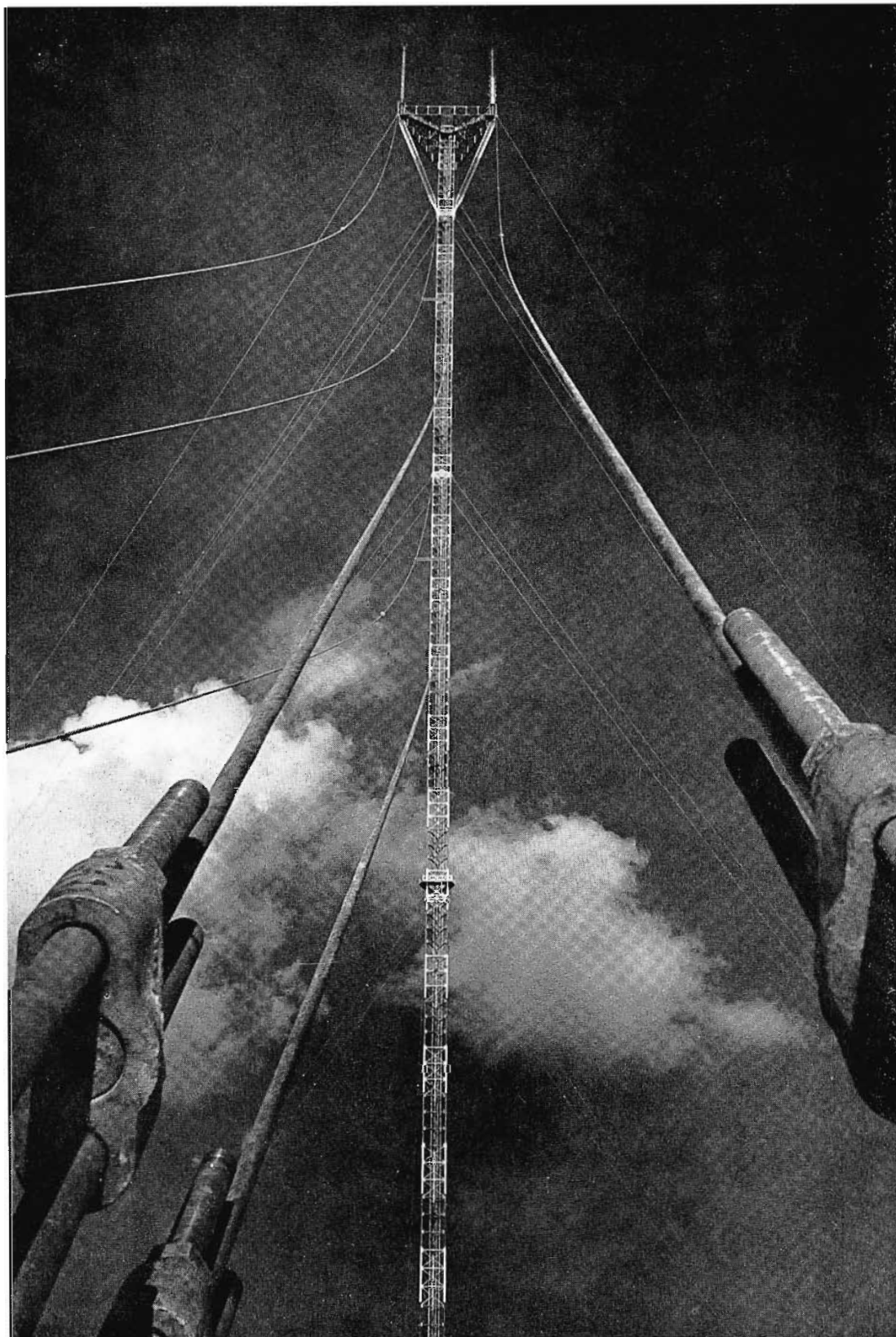

This interesting photo, sighted through Hill Tower's massive guy anchors, shows the KRLD-TV antenna (right) and the WFAA-TV antenna (left). Security of the tower is provided by sturdy guy cables up to two inches in diameter.

Line of sight distance from the top of the tower to the horizon is approximately sixty miles. The tower is designed for sixty pounds per square foot pressure on flat surfaces above the 760 foot level and for forty pounds per square foot pressure below this level. This is equivalent to a design for 159 miles per hour winds.

TOWER PROPER

The tower proper is twelve feet wide on a face and triangular from ground to

top. Legs are solid Mayari* steel rounds, varying with elevation from ten inches to four inches in diameter. They were fabricated in thirty foot sections. Diagonals are solid rounds varying from one and one-half inches to one inch in diameter. Girts are double angles. Leg splice connections are

* Trade name for Bethlehem Steel Company's high strength steel.

Photos, courtesy of Hill Tower, Inc., KRLD-TV, WFAA-TV, Dallas Morning News, Dallas Times Herald, Dresser Industries.

made with alloy drive bolts. Main girts and diagonal connections are alloy steel drive bolts. All other connections are standard machine bolts. All bolts have lock nuts or lock washers.

GUYS

There are five sets of double guys in each of three directions—for a total of thirty guys. The tower is guyed at 290 foot, 650 foot, 1010 foot, 1310 foot, 1419 foot levels and also at bottom corners of the 80-foot platform. Guys are galvanized bridge strand steel cable varying from $1\frac{3}{8}$ inches to 2 inches in diameter. They have breaking strengths ranging from 490,000 pounds down to 232,000 pounds. The guys are fitted with dampener weights at unequal spaces to prevent harmonic vibrations . . . a whipping action in the cable set up by a steady impulse of wind causing heavy loads at guy pull-off points. Dampeners on the lower set of guys weigh 150 pounds each. On the other sets of guys they weigh 350 pounds each. Guy anchors for the lower two sets of guys are 650 feet from the tower base. Anchors for the upper three sets of guys are at 1050 feet from the tower base.

TOP PLATFORM

The top platform is an open steel framework. It is triangular and is 80 feet wide across each side. It is mounted at the very top of the tower and is supported at each of the three corners by a truss which runs up and out diagonally from the 1310 foot level of the tower to each bottom corner of the platform. Each diagonal truss is 108 feet long. Catwalks run out from an elevator landing in the center of the platform to the three corners of the platform. The third corner is counterweighted to keep the platform in balance with a 10,000 pound scrap steel counterweight. The platform is twelve feet deep. At each corner it is built up another 4 feet 5 inches for antenna support.

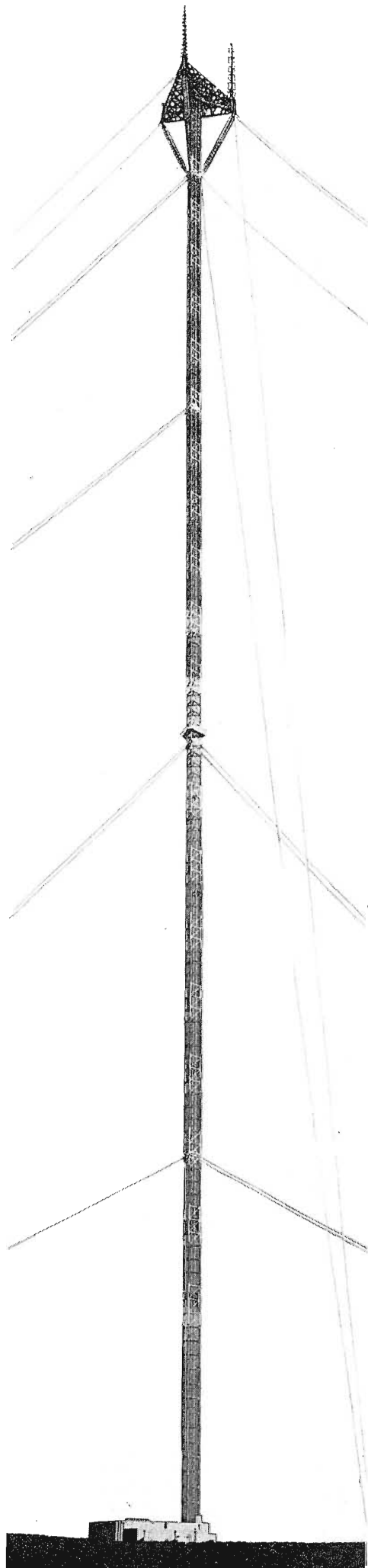

A full view from ground to antenna beacons shows all of Hill Tower's 1521 feet.

TWO MAN HOIST FOR TOP-TO-BOTTOM TRANSPORTATION

A two passenger elevator running from the ground up to the landing on the top platform is operated by Ideco's new electronic control system.

LIGHTING SYSTEM

1,000 watt beacons are mounted on each antenna and on a pole at third corner. 500 watt obstruction lights are located in the plane of the platform. A pair of 1,000 watt beacons are located at each of the following levels: 1200, 900, 600 and 300 feet. There is a group of three obstruction lights (one on each corner) at each of the following levels: 1300, 1050, 750, 450 and 150 feet.

FOUNDATIONS

The center pier foundation is a hexagon which measures 33 feet between parallel faces. This center pier is 13 feet deep and is mounted on a 3-foot deep pad. Two hundred cubic yards of concrete were used in the center pier. Its design was based on a maximum soil pressure of 6000 pounds per square foot. The inter-guy anchors measure 10 feet deep by 12 feet wide by 17 feet long. They are buried 10 feet beneath the grade line and each contain 150 cubic yards of concrete. The outer guy anchors are 27 feet by 23 feet by 13 feet 6 inches deep. They are 13 feet 6 inches below grade and they each contain 320 cubic yards of concrete.

MISCELLANEOUS

A four foot wide outside platform is at the 650 foot level on which two 6 foot in diameter micro-wave antennas and two micro-wave reflector screens will be mounted. Four $6\frac{1}{8}$ inch diameter coax lines will be installed in the tower with provisions for installation of two more in the future. Ground run of the transmission lines is 172 feet out to the northeast for KLRD-TV and 161 feet out to the northwest for WFAA-TV. The John F. Beasley Construction Company, 402 South D Street, of Muskogee, Oklahoma, was the erection sub-contractor.

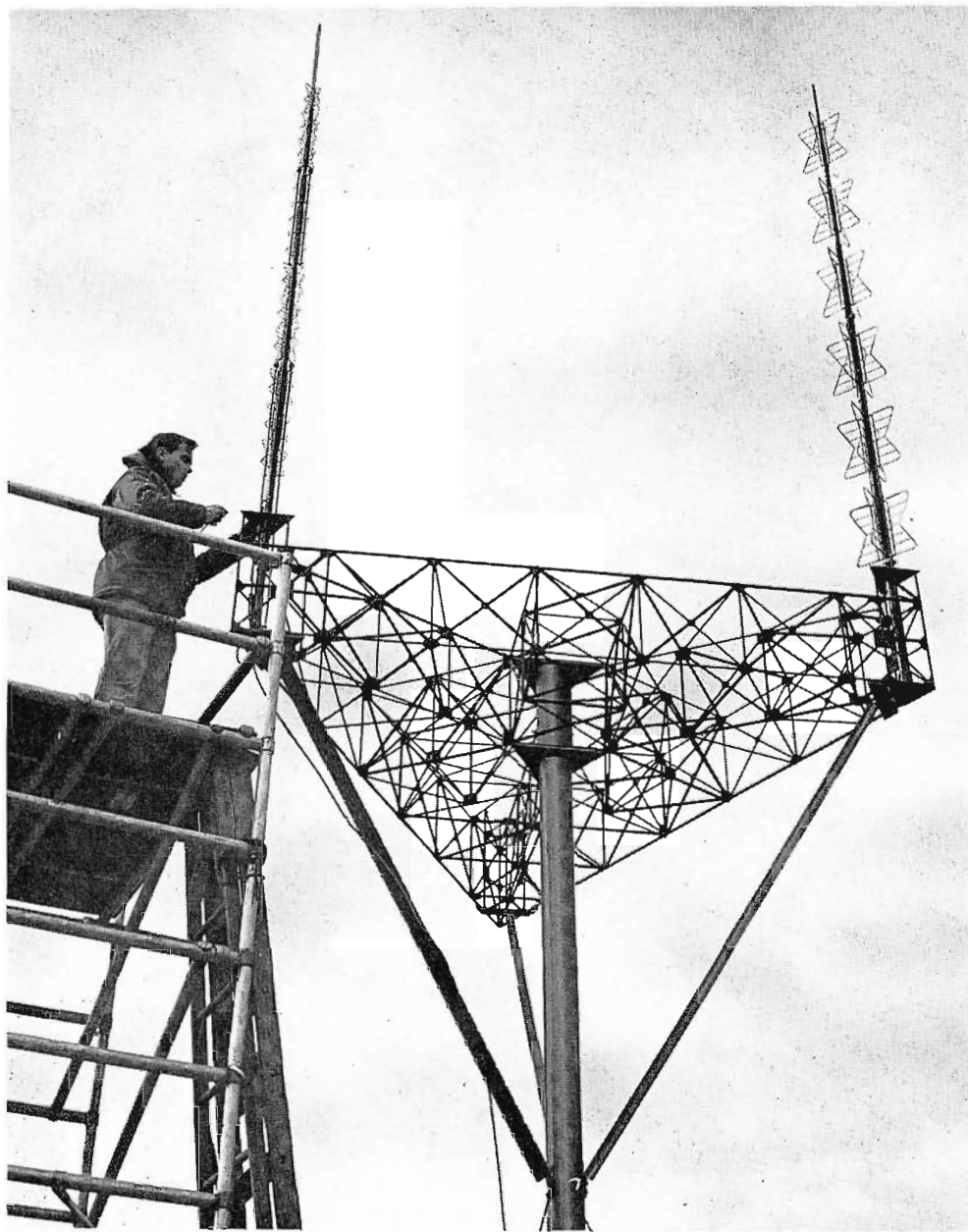

To acquire performance data on antennas mounted side-by-side in reasonably close proximity, working model antennas built to one-tenth scale and operating in the region of 500 to 1500 mc. were used. The supporting triangular platform is also a scaled replica of the completed installation.

DEVELOPMENT OF THE "CANDELABRA" ANTENNA SYSTEM

By L. J. WOLF
Project Manager
Engineering Products Division

Equipment for Hill Tower, the most unusual multiple TV antenna system in the southwest United States, was manufactured by RCA in Camden, N. J. to enable stations KRLD-TV and WFAA-TV to broadcast from Superturnstile antennas on top of a 1,438-foot tower located between Dallas and Fort Worth. The antenna supporting structure is a triangular guyed tower with an 80'-3" triangular platform at the top to support the antennas. This tower was designed and built for RCA by the Dresser-Ideco Company. This new facility provides greatly improved television service to northeast Texas.

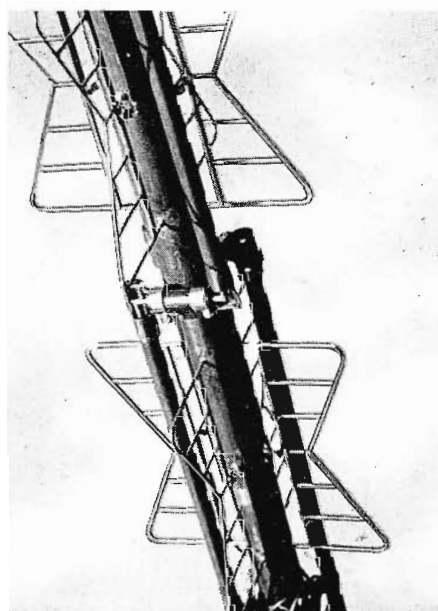

ARRIVING AT SPECIFICATIONS

The specifications from each of the consultants for WFAA-TV and KRLD-TV required that the top of each antenna be at the maximum height permitted by the C.A.A. For the specified height of 1,521 feet to the antenna beacons a single tower with a top platform was computed to be less expensive than two separate towers.

RCA has built several multiple antenna systems, including the vertically stacked arrays on the Empire State Building in New York City¹ and on the Foshay Tower in Minneapolis², however the equal-height requirement for WFAA-TV and KRLD-TV

◀ Resembling a full-scale Superturnstile, the close-up of the scale model shown here points out the precise construction of bat-wings and transmission line feed—a "must" for accurate results.

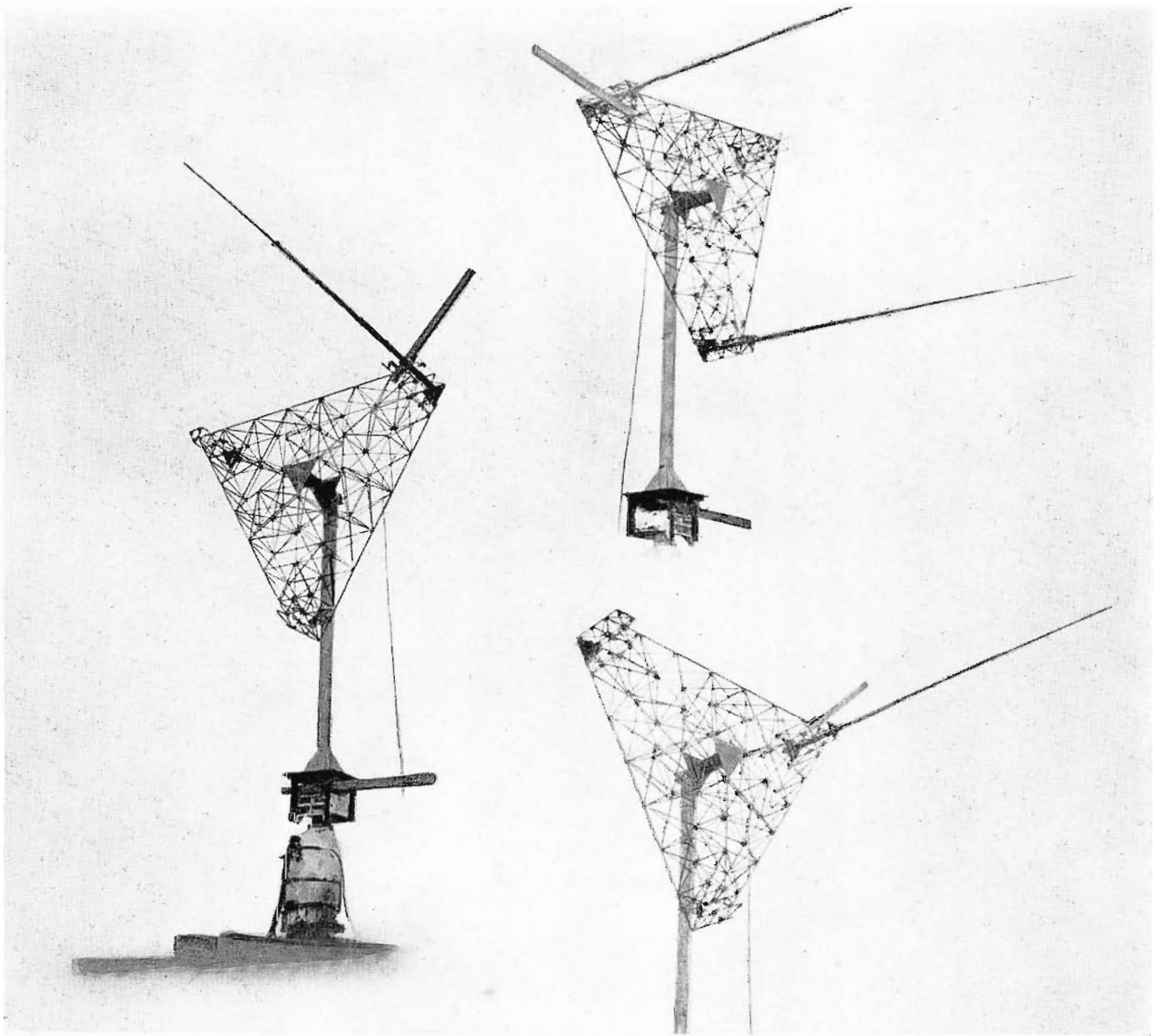

At RCA Moorestown, N. J. Antenna Test Site, scale models of the RCA "Candelabra" Antenna System are conveniently tilted to obtain radiation patterns at various depression angles.

precluded systems such as these, hence the alternate "Candelabra" arrangement was used.

As an aid in co-ordinating a target specification with the two consultants, RCA had available the results of previous work on the mutual effects of antennas in close proximity—and also of the effect of nearby shielding objects on the performance of an antenna. The data on this latter effect was applicable in this case since each antenna could be considered as a shielding object to the other.

Conferences were held with the station engineers and with the consultants retained by the stations. The target specification agreed upon contained the following principal items:

A. Horizontal pattern of each antenna in the presence of the other to have a deviation no greater than ± 3 DB.

Miniature feedlines were constructed of teflon-covered copperweld wire drawn into small copper tubing achieving proper characteristic impedance.

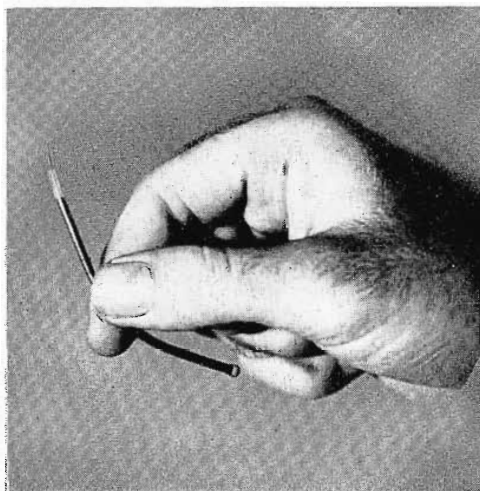

- B. The power gain of each antenna to be affected no more than 0.5 DB by the presence of the other antenna.
- C. The cross-coupling between the N-S and E-W radiator systems of each antenna in the presence of the other to be no greater than -26 DB.
- D. The cross-coupling between the two antennas to be no greater than -26 DB.
- E. The input impedance of each antenna in the presence of the other to match the transmission line to a VSWR of 1.1 or better.

PERFORMING PRELIMINARY ANTENNA TESTS WITH SCALE-MODEL ANTENNAS

It was decided to perform the tests with scale model antennas at ultra-high frequencies in the region from 500 to 150 mcs, since test equipment and a suitable test



An existing tower (also see photo at right) at the Camden Test Site provided various heights for mounting "dish" receiving antenna. Rotating pedestal and test house can be seen in the background at extreme lower left.

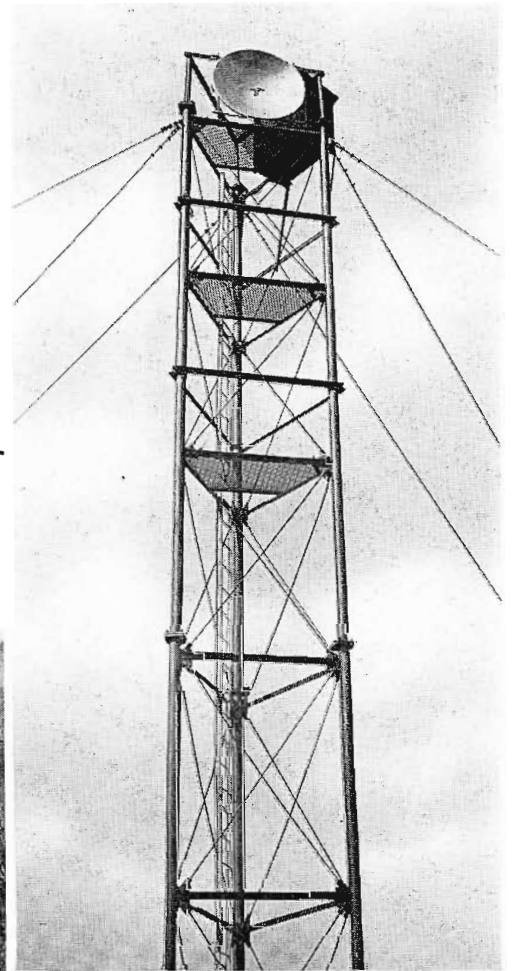

Tower with receiving parabola for pick up of scale model radiated signals.

site was already in existence at RCA. The site consisted of cleared terrain with a rotating pedestal for the scale model antennas, and a tower located at a distance of 1400 feet from the receiving equipment. A shallow valley between the pedestal and receiving tower aided in minimizing ground reflection effects.

The test equipment used for the radiation pattern tests consisted of a calibrated signal generator which fed the antenna being tested. At the receiving tower, a parabolic antenna picked up the received energy which fed through a dipole and rectifier into an amplifier which transmitted the audio component over a buried telephone line to the transmitter location where a recording meter made a record of the pattern as the transmitting antenna rotated on the pedestal.

In making the scale models great care was required in order to make sure the re-

sults would be applicable to the full-size units. The poles were constructed of sections of tubing, telescoped to the correct scale dimensions. The batwing-shaped radiators were constructed of brass rod, soldered together and shaped to scale. The feedlines were constructed of teflon-covered solid copperweld wire which was drawn into copper tubing so that the outside diameter and the characteristic impedance were correct. The scaled $3\frac{1}{8}$ inch transmission line, $\frac{3}{8}$ inch in diameter, was constructed of copper tubing with wafer insulators of teflon to maintain the required $51\frac{1}{2}$ ohms impedance. The junction boxes connecting the feedlines to the $51\frac{1}{2}$ ohm transmission line were the only components not exactly scaled; however these were made electrically equivalent to the full-size counterparts.

As a result of this care in making the models, the electrical performance was

equivalent to the full-size antennas. For instance the input VSWR of the 6-section model antenna was 1.4 as received from the model shop and required only a small adjustment to make the impedance correct, with a VSWR better than 1.1 at the scaled frequency. The scale model of the 12-section TF-12AH antenna required a little longer time to obtain the 1.1 VSWR limit, due to the higher frequency which was nearly 1500 megacycles.

The tests, to prove that the models had the same pattern shape and gain as their larger counterparts were made with the models supported horizontally on a rotatable pedestal mount. The shape of the patterns together with the beam widths, null positions and lobe amplitudes showed excellent agreement with measured and calculated patterns of the TF-6BM and TF-12AH antennas—hence the scale models were suitable for further tests.

Scale model of TF-12AH Superturnstile under impedance test.

In order to determine the coupling effect of each antenna model on the other, a triangular platform was constructed to scale from the drawings of the 80-foot triangular platform proposed for the tower top. This was mounted on the pedestal with the two scale models in place.

The horizontal pattern measurements were made with this arrangement which showed that the gain of each model was affected only negligibly by the presence of the platform and the other model. This was double-checked by mounting the platform vertically so that the scale models were horizontal; with this arrangement the vertical patterns could be recorded and compared with the patterns previously taken of each scale model by itself. The resultant data checked quite closely and also showed that no discernible pattern tilt existed due to reflection from the platform. This latter was an important result of the tests since the success of the whole project would have been in question if there were an upward tilt to the beam radiating in the direction across the platform.

The tests on intra-coupling within each model and inter-coupling between models were performed on the triangular platform. The effects were very small as shown in the tabulation which follows. The input of each model was measured with and without the presence of the other model and here too, the effect was found to be negligible.

COMPLIANCE WITH TARGET SPECIFICATIONS

The tabulation table on page 16 shows the degree of compliance with the target specifications.

INSTALLATION SPECIFICATIONS

The actual installation was made with the antennas separated 75 feet, which was the predicted minimum spacing. The top platform is constructed with a triangular shape, even though one corner will be unoccupied by an antenna. This triangular shape is used so that the platform will conform to the cross-section shape of the three-sided tower. The tower is of uniform cross-section and is 12 feet on a side, supported by five sets of double guys. It is designed to RCA specifications by the Dresser-Ideco Company in accordance with the results of the tests described above. The tower lighting is accomplished by eleven sets of lights, at eleven levels including the beacons on top

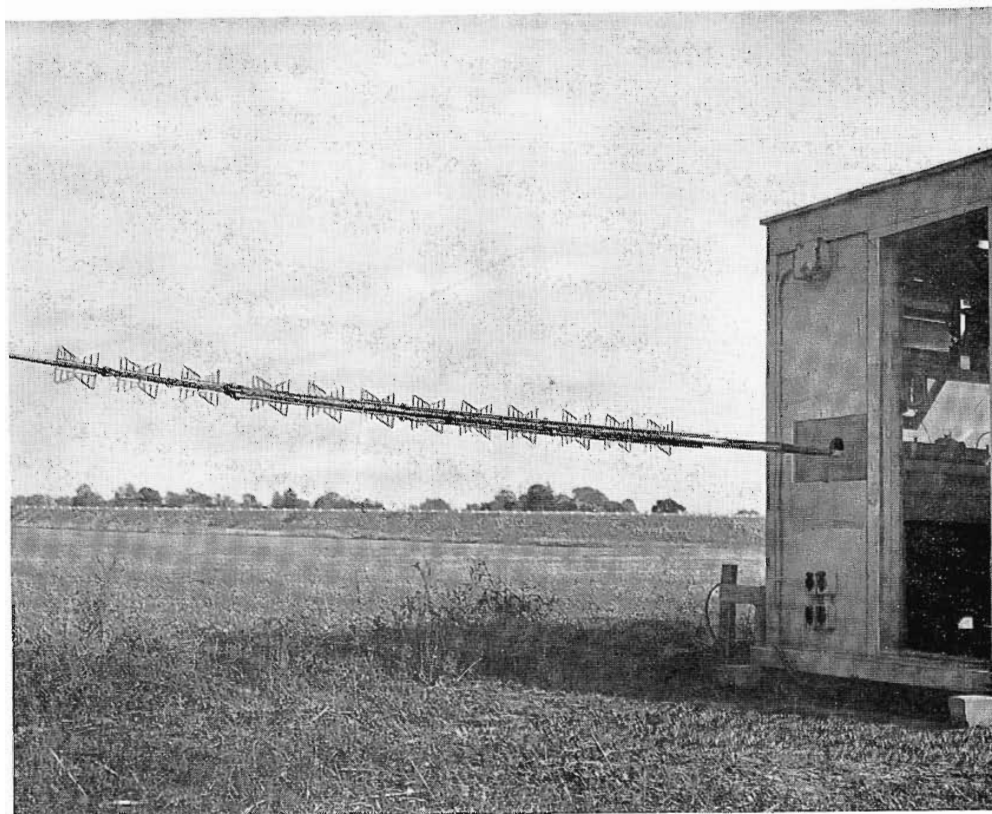

TF-6BM scale model on pattern test set-up.

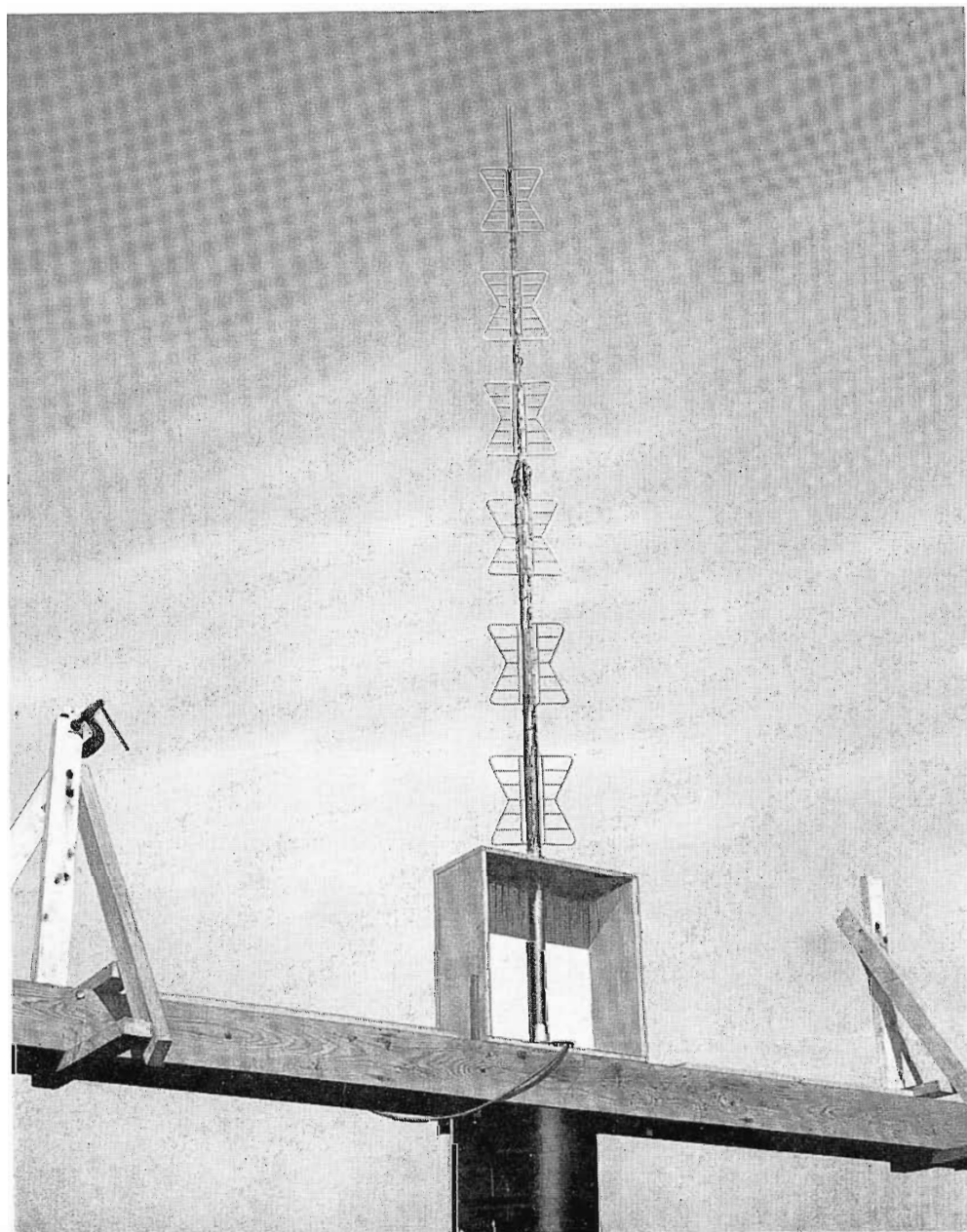



Pedestal used for rotating antennas. Cross arm and two end supports are ready to receive model antenna for pattern measurements.

of the antennas. At the other levels 1000 watt beacons are alternated with triple-100 watt fixtures. Access to the antennas is facilitated by a two-man lift within the tower, and a ladder as well. A grating in the platform permits access to the antennas, meanwhile providing protection to personnel.

Each antenna is fed by a twin run of $6\frac{1}{8}$ coaxial line, supported within the tower and positioned for easy access from the lift and the ladder.

FUTURE POSSIBILITIES OF THIS TYPE OF MULTIPLE ANTENNA SYSTEM

The trend toward increasing heights for transmitting antennas, up to the maximum heights permitted, gives greater importance

to the side-by-side type for multiple antenna installations, since it is now possible to provide a multiple installation with the antennas at equal heights.

On most systems of this type a single authority, such as a Primary Committee or the equivalent, has been set up to co-

ordinate the station's and consultant's specifications with the manufacturer. In the case of KRLD-TV and WFAA-TV this was accomplished by a mutually owned company, Hill Tower, Inc., which not only does the co-ordination work but which also owns the mutually used facilities.

Table showing results of scale model antenna tests.

Test Designation	Target Specification	Results of Scaled Antenna Model Tests	
		Channel 4	Channel 8
A. Horizontal Pattern	± 3 DB max.	± 2 DB	± 3 DB
B. Gain	To differ not more than 0.5 DB from published value	Vertical and horizontal patterns unaffected by presence of channel 8 model hence gain is unchanged	Vertical and horizontal patterns unaffected by presence of channel 4 model hence gain is unchanged
C. Cross-coupling within antenna	-26 DB	-32.5 DB	-36.6 DB
D. Cross-coupling between antennas	-26 DB	-47 DB	-44 DB
E. Input impedance	VSWR not to exceed 1.1	No change due to presence of channel 8 model	No change due to presence of channel 4 model

Close-up of scale model tower top upon which model antennas were mounted for testing.

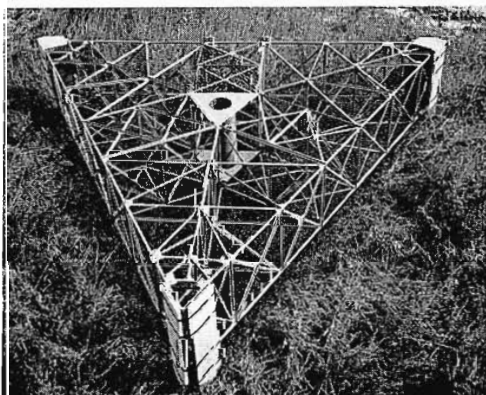

The success of this project shows that a complete system consisting of antennas, transmission line and tower can be undertaken with a certainty of success.

All of this equipment, including the assembly and erection, was handled as a package by RCA, thus assuring complete coordination and single responsibility.

ACKNOWLEDGMENT

Acknowledgment is due for the success of the field work on the project to R. H. Wright, J. V. Hyde and G. E. Erwin, engineers in the Engineering Products Division, who did the field test work on the models, much of which was accomplished during adverse winter weather.

References

¹ J. B. Dearing, H. E. Gihring, Raymond Guy, F. G. Kear, "Multiple Television and Frequency-Modulation Transmitting Antenna Installation on the Empire State Building". Proc. I.R.E., Vol. 41, No. 3, March 1953.

² John M. Sherman, "WCCO-TV and its 100,000 Watts ERP". BROADCAST NEWS, Vol. 75, page 26: July-August 1953.

Pattern measurements are taken with antennas mounted on turntable to measure radiation in all directions and to determine cross-coupling result.

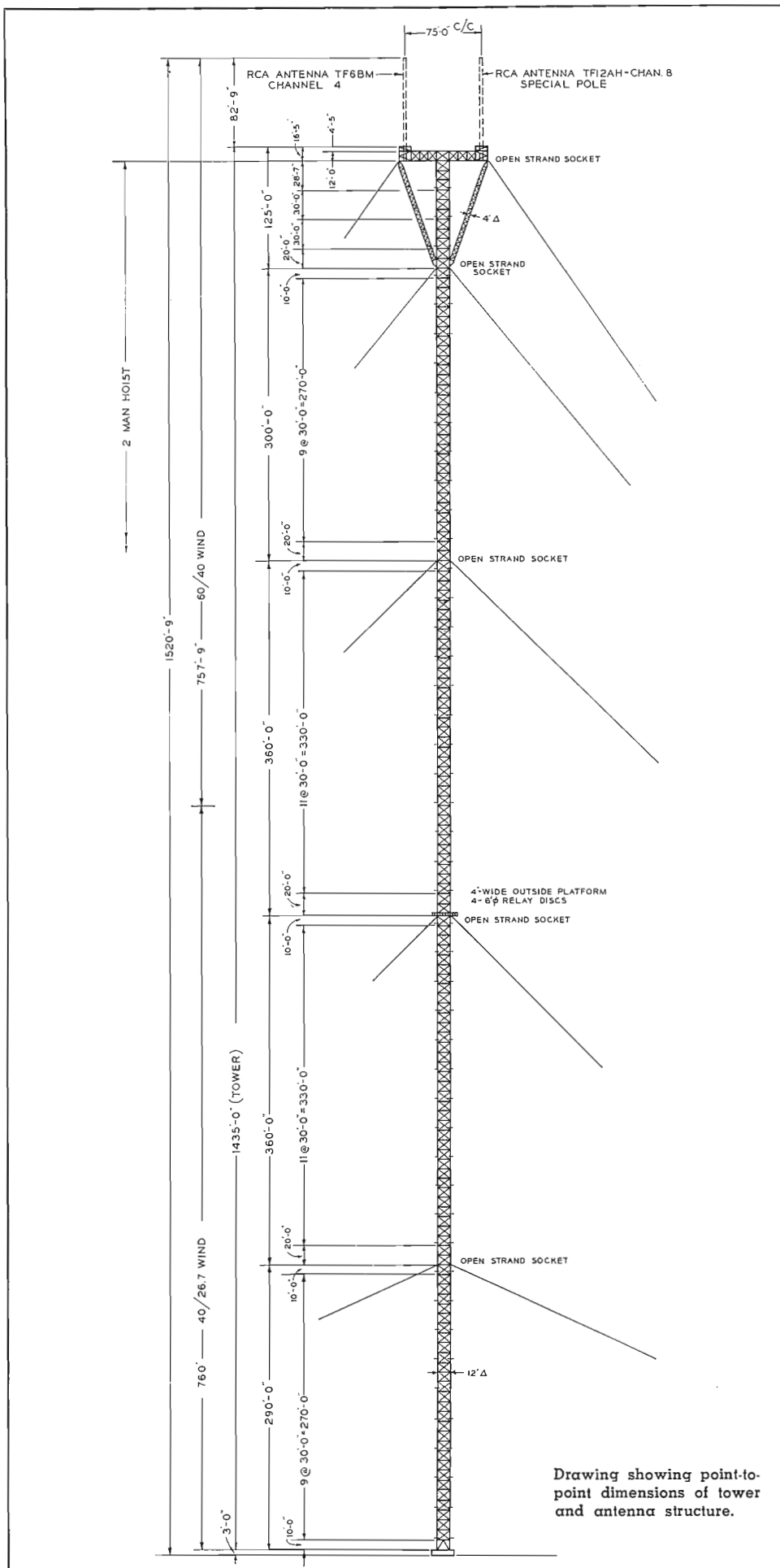
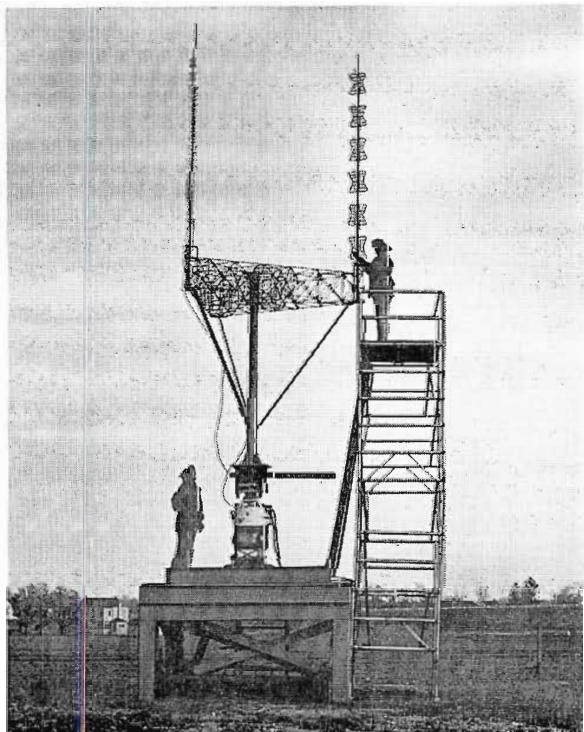

Drawing showing point-to-point dimensions of tower and antenna structure.

CONSTRUCTION AND ERECTION OF THE RCA "CANDELABRA" ANTENNA SYSTEM

FABRICATION OF HILL TOWER AT THE IDECO PLANT

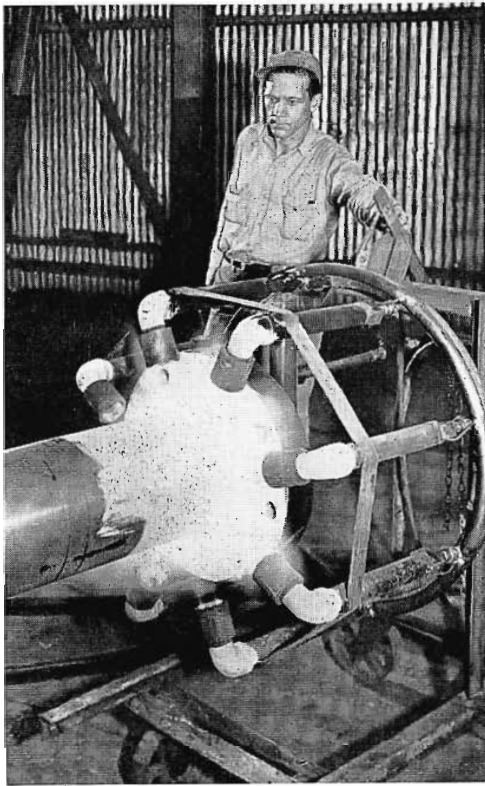

Jig welding of a flange on a round tower leg member by means of a jet welding device.

Rigid requirements for a structure as tall and of such physical proportions as Hill Tower imposed stringent demands on fabrication techniques. Well experienced with projects of this scope, the Dresser-Ideco Company was able to provide plant facilities with the most modern equipment ever devised for machining and assembling tower components. Photos on this page show a few of the many operations involved in producing tower members and fittings.

At left—a circular jet welding device bonds a flange to a vertical round member with tremendous but even heat—a modern technique that assures unflinching strength.

Below—gusset plates are being welded to solid round members to accommodate

the horizontal and diagonal tower members. Following this operation they are sorted and tagged for shipment. No field fabrication is necessary. Towers built for RCA are shipped ready for rapid assembly. Shop fabrication to close, predetermined tolerances means fast erection and no chance of tower misalignment during erection. Machine-shop jig drilling and jig welding is a practice that further assures accuracy. Units or members are pre-tensioned—completely eliminating inaccurate adjustments in the field.

Tower structural members are completely hot-dip galvanized and all parts are coated with zinc to prevent rust . . . an Ideco fabricated tower does not rely on paint for protection against the elements.

Sorting and tagging finished vertical leg members is a necessary chore for future identification purposes.

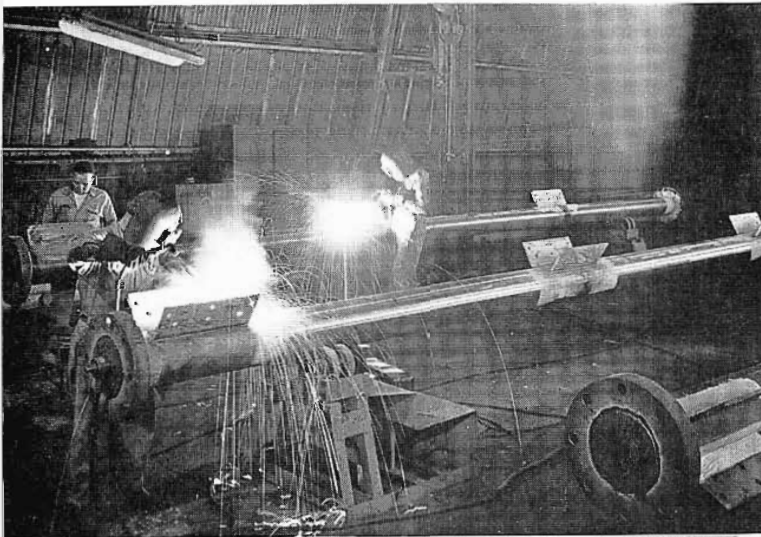

Welding gusset plates into position on round tower leg members. The accurate positioning requirement for these plates is quite evident since tower horizontal and diagonal members will be fastened to them.

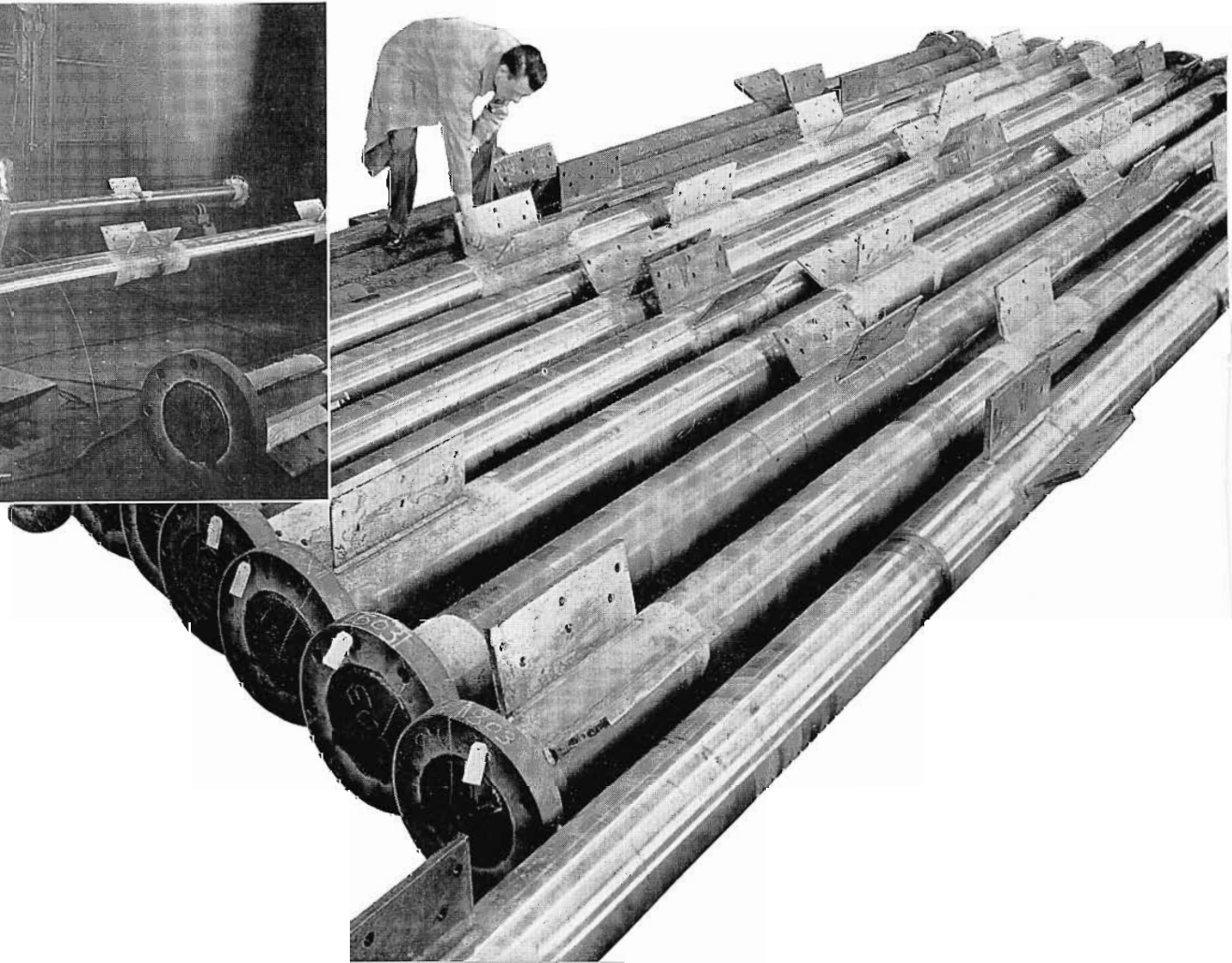

THE HILL TOWER STOCKPILE



Solid rounds 30 feet long by 10 inches in diameter are hoisted from gondolas to waiting trucks.



Tower diagonal-bracing members are unloaded from trucks at the stockpile area.



Orderly layout of tower components proceeds with skillful handling.



An old tree seems to offer shelter for some 50 kegs of bolts—"no need, they're galvanized!"

After arrival of tower components at the erection site near Dallas, a mammoth job of materials handling began. Gondolas loaded with 30-foot-long solid round vertical tower members, cross-bracing members and other components were unloaded and materials transferred to trucks for delivery to the stockpile area. Temporary buildings at the erection site became virtual "hardware stores."

The fact that accumulation of a lot of material is required on a project of this size is verified by the photos on this page! In addition, accurate inventory is a "must" in order to keep construction rolling on schedule. Lost time for a lost bolt cannot be tolerated here, where time means money. Thus, the Hill Tower stockpile, spread out over many acres, was complete in count and located in strategic positions for the most efficient order of assembly. Again, experience and know-how assured that the flow of components would be uninterrupted and in proper sequence for rapid assembly.

The chart on page 11 gives an interesting account of the enormous quantities of various materials which were stockpiled prior to their incorporation into the finished product known as Hill Tower.

Reel-after-reel of cable stands ready to roll into action at the first call for tower bracing. An assortment of cable diameters ranging from 1 3/8 to 2 inches are stored here.



Electrical Supplies: Conduits, wire, light beacons, bulbs and fittings for Hill Tower's visual night warning signals.

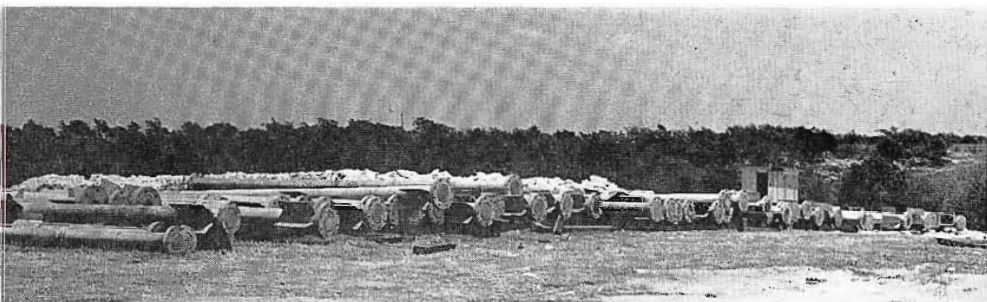

"Battle wagon cannons"? No! . . . solid round vertical tower members up to 10 inches in diameter, 30 feet long and made of Mayari steel—a steel of superior high strength.





Placing reinforcing steel in tower foundation pits. A total of 35,000 pounds of steel was used for this purpose.

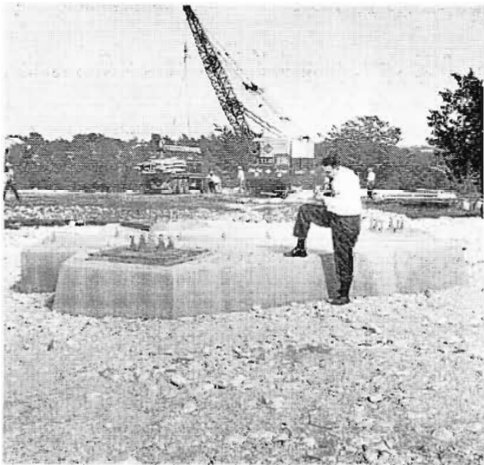

One of many typical guy anchorage piers with steel plates in place.

PREPARATION FOR ERECTION

While materials are being stockpiled, much activity is in progress preparing excavations for tower foundations and pursuing the many other operations that must take place before actual tower assembly can begin. Pits are blasted from solid rock. Thirty-five thousand pounds of reinforcing steel are being placed honeycomb fashion in the many pits required for pouring the guy anchor foundations and the main center pier. The complete tower site is graded and drainage provided.

The tower foundation pits with their reinforcing steel in place are made ready to pour thirteen hundred cubic yards of concrete—an operation that keeps the cement mixers pretty busy making continuous trips in an unbroken chain.

The base plates on which the three legs of the tower sit, each weighing three tons, are fitted into exact positions on the main tower center pier and other steel plates are positioned for securing guy anchors.

A plot of 305 acres is made ready to accommodate the main tower structure and

the guy cables which will stretch out to distant points from the main structure. The total length of all thirty guy cables totals 7.625 miles.

Round vertical leg members are brought up into position for starting the tower structure along with horizontal and diagonal members which will form the first basic structure section.

Much of the time consumed in an operation of this size takes place in the preparatory stages. It is here that the plan takes shape in the form of a precise layout of foundations and placement of components that determine the ultimate accuracy and dependability of the structure. It is here that experience counts and the skills of many men are depended upon.

From this point on, rapid assembly of the tower structure can take place in a pattern of sequence that repeats its plan for many hundreds of feet—with men who know their business performing skillful tasks every step of the way.



Solid round vertical members are moved in position for quick reach as tower steel is put in place at the beginning of construction.

EARLY STAGES OF ERECTION

Early stages of erection are shown here from the time the first tower legs were set in place until approximately half of the full tower height was reached.

Ceremonies took place as the first steel was set in place. Representatives of The Dallas Morning News, WFAA-TV and The Dallas Times Herald, KRLD-TV were on hand to witness this auspicious occasion. The date was May 18, 1955.

Day after day (with weather conditions permitting) each 30-foot section was put in place to form a consecutive pattern of vertical, horizontal and diagonal members, gradually increasing in height. As the structure took shape, the pattern from bottom to top was unchanged except for a 4-foot outside platform skirting the tower at the 650-foot level. This platform would accommodate two 6-foot-diameter microwave antennas and two microwave reflector screens.

Each day steel workers performed what we would consider feats of daring beyond comprehension as they rode the steel weight called the "headache ball" to lofty heights.

Winch operators, crane operators, riveters—men with many responsible jobs to do—appeared each day to accomplish his particular task in a matter-of-fact way, because these are their skills.

As the tower structure progressed, temporary guys were attached. Then as more lofty heights were reached, the tower took on a network of permanent steel guy cables which spanned out in pairs from the corners of the tower to the steel reinforced concrete anchors buried in the ground and located almost a fifth of a mile from the tower base. The cables, some of them 2 inches in diameter, were fitted at intervals with heavy steel weights to prevent harmonic vibrations which might be set up by the wind. The large cables were designed to withstand pulling stresses of as much as 245 tons.

The progressive stages of the erection of Hill Tower were swift because of many factors—experience, excellence of design, earlier precision fabrication, all-round understanding of the job at hand and the ability to coordinate the efforts of many people.

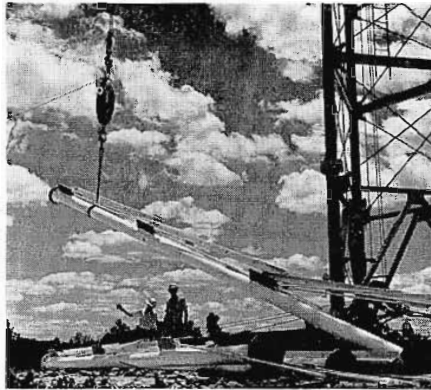

Lower vertical tower members are hoisted into place. They are solid round members 10" in diameter.



Rapid assembly of the tower structure is made possible by well-planned design and precise fabrication.

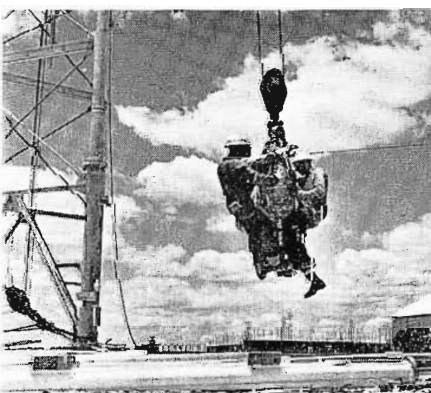

All in a day's work, steel workers start their ride up to lofty heights on an egg-shaped steel weight called the "headache ball".



Nearing half-way mark the pattern of the tower structure repeats itself every 30 feet.

ADVANCED STAGES OF ERECTION



Riding the "headache ball" provides a birds-eye view of Dallas and the surrounding area.

At this stage of erection men still ride the "headache ball", continually busy with the task of fitting and bolting new sections in place and attaching guy cables to their pull-off points. At this point the top platform, which would accommodate a small home, is now under construction.

The interesting aerial photo at the right shows preliminary construction of the 80-foot triangular platform. It begins as three out-rig sections which will have further sections added to form the triangular shape. If lines are drawn by placing a straight-edge at the ends of the out-rig members, a triangle as large as the finished platform will be formed. The point nearest you as well as the other two points will coincide with the triangular symmetry of the tower.

This look-down view of Hill Tower in advanced stages of erection was taken by The Dallas Morning News. It shows preliminary stages of construction of the 80-foot triangular platform.

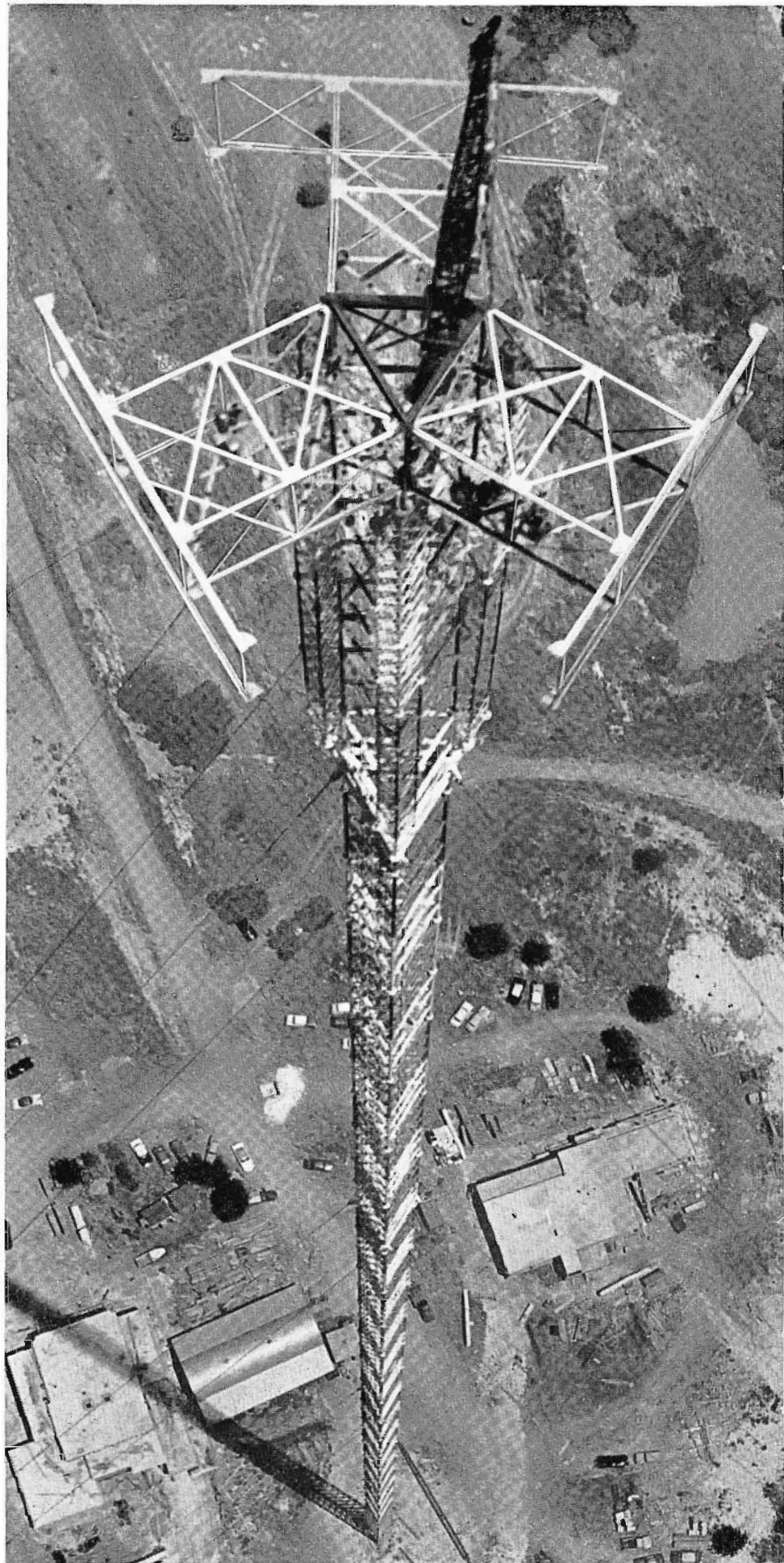

"TOPPING OUT"

"Topping Out", a term used in the building trade to indicate finishing out a structure, applies here to Hill Tower.

The immense 80-foot superstructure, braced by three diagonal trusses 108 feet long, is now in place ready to receive the two antennas. A husky gin pole, at the tower top, is set to do its job of lifting fully-rigged antennas and setting them into pole sockets which are located at extreme ends of the triangular platform. The antenna pole sockets extend above the top platform a distance of approximately $4\frac{1}{2}$ feet and into the platform to a depth of 12 feet for a total of $16\frac{1}{2}$ feet. This provides rigid support for each antenna.

As the photo at the right shows, guys are firmly anchored in their husky concrete piers—each made up of 320 cubic yards of concrete.

The following pages show scenes of the antennas, which form the "Candelabra" antenna arrangement, being hoisted into position atop the 80-foot triangular platform. With these operations, Hill Tower is completed, furnishing facilities for WFAA-TV and KRLD-TV to provide extended coverage and a greatly augmented audience.

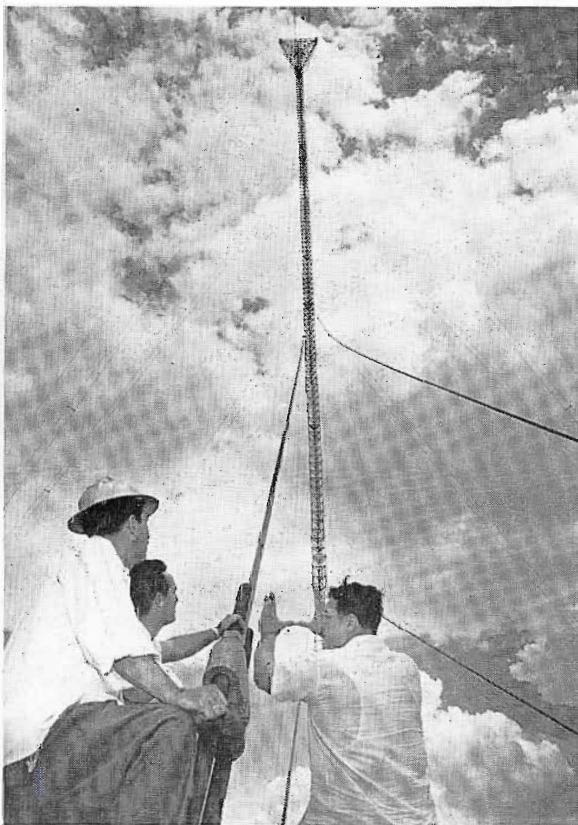

Gestures are being made in order to size up a few good tower shots from the guy anchor position. Proof of this planning is evidenced by the excellent photos provided by Dresser Industries.

From guy anchorage to tower top with gin pole ready for action.

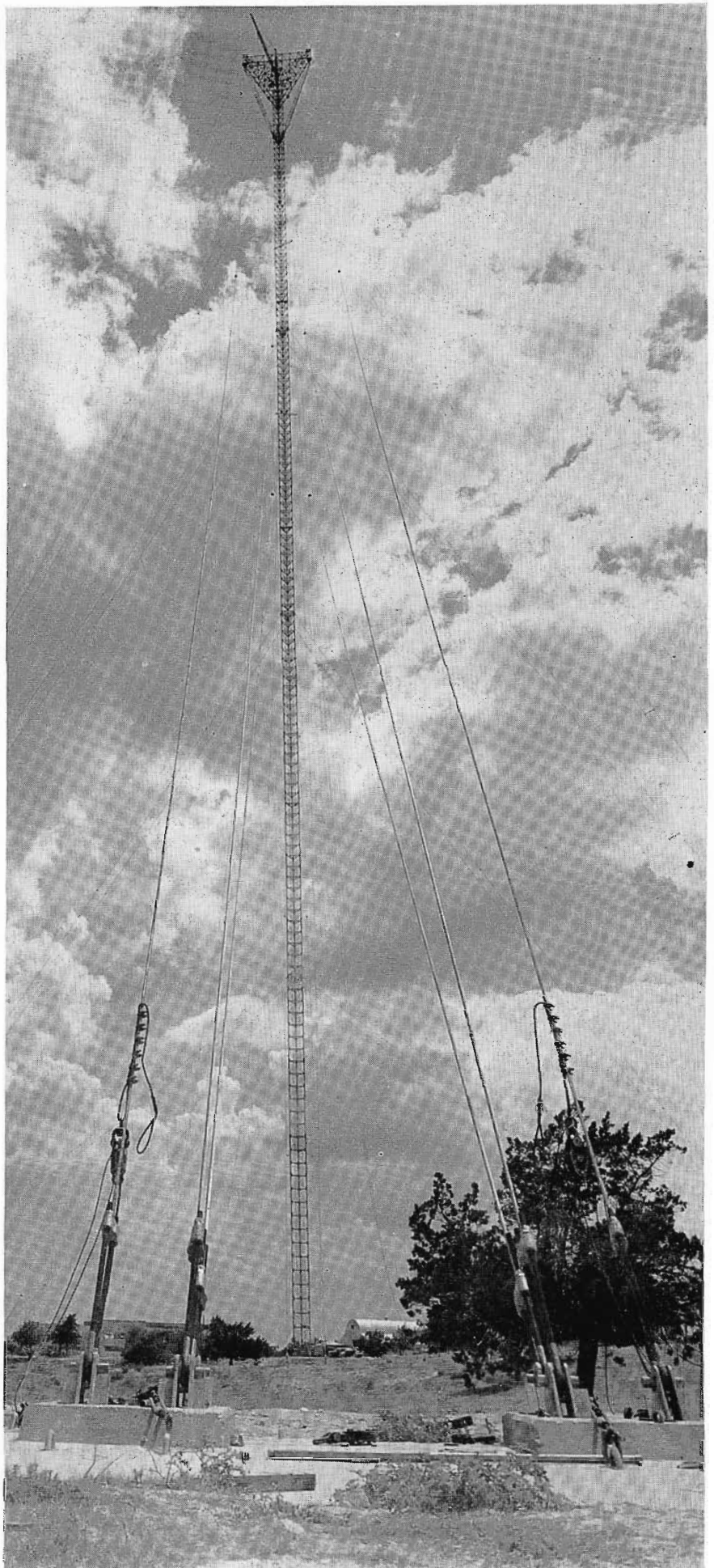

UP GO THE ANTENNAS

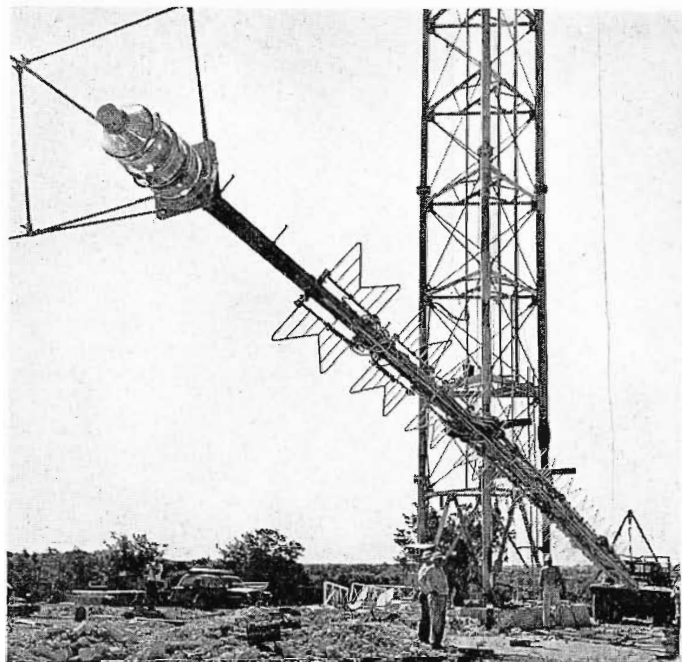

RCA TF-12AH 12-section Superturnstile starts its long journey to the top tower platform. Upper left corner shows detail of beacon and lightning protector.

Last minute rigging adjustments are made en route to the top.

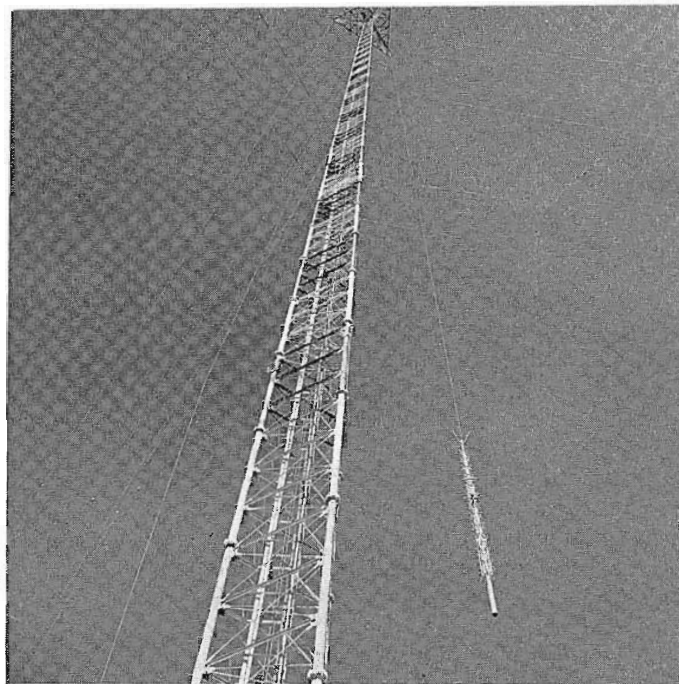
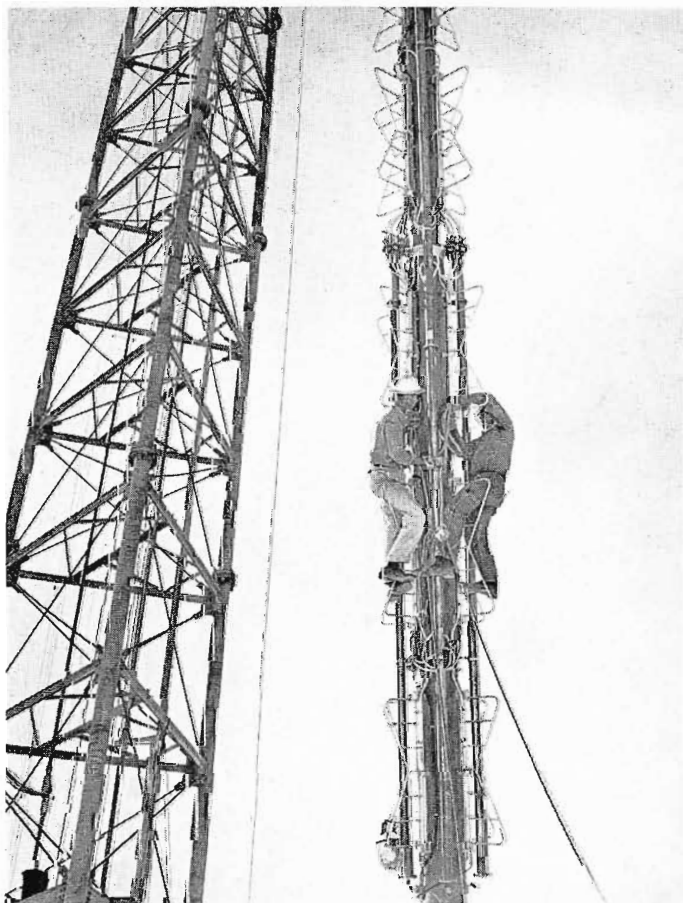

On its way up, the WFAA-TV Channel 8 antenna is carefully guided towards the corner of the triangular tower which it will occupy.

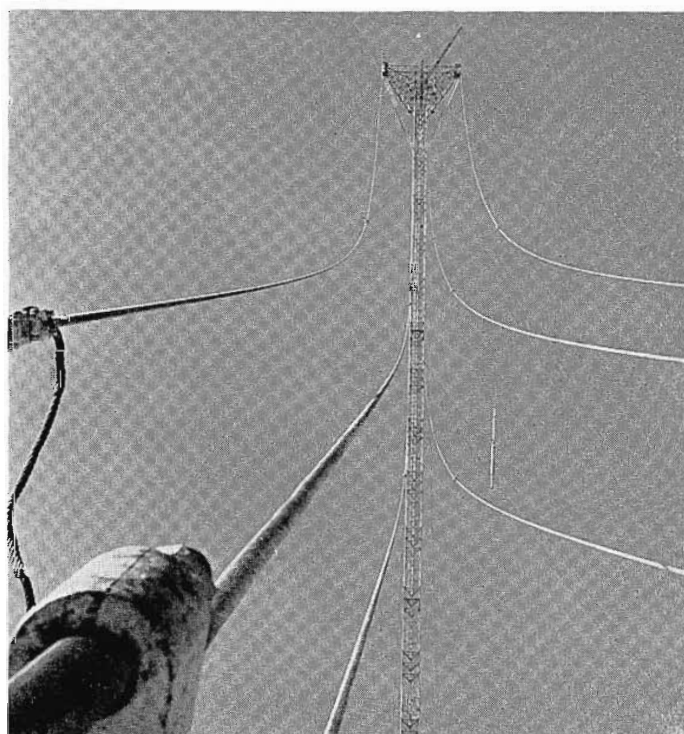

Nearing the half-way point the antenna which is big on the ground looks insignificant in the air.

Almost like a match-stick the antenna, which is dwarfed by height, is ready for lowering into its receiving socket.

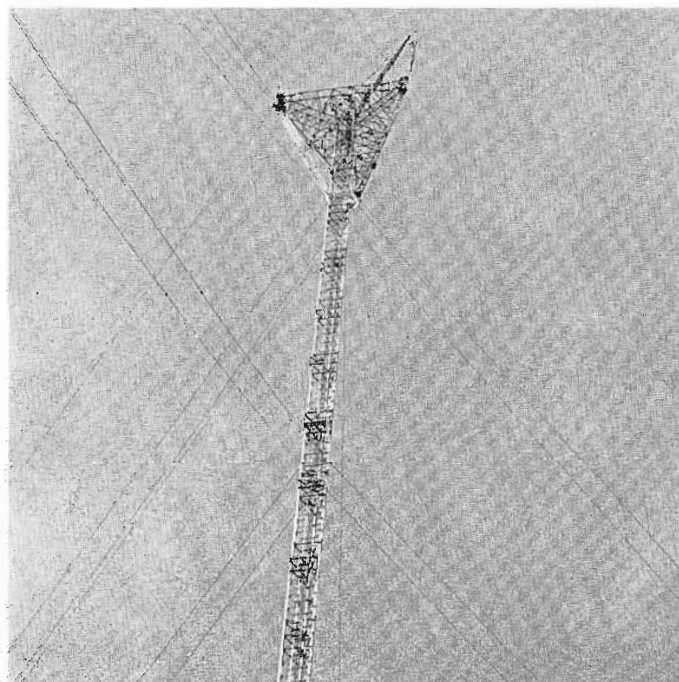

READY FOR OPERATION

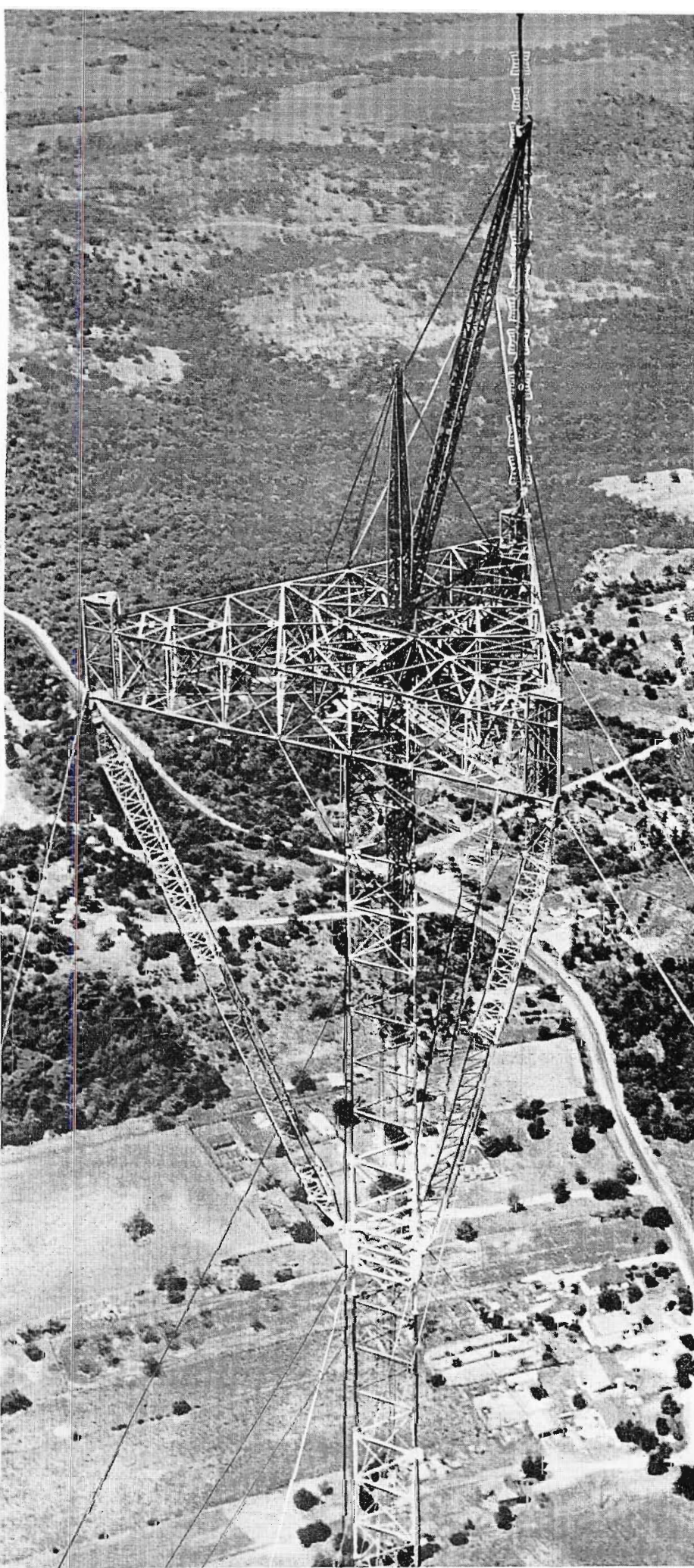

ABOVE—Nearing final construction, this aerial view, taken by the Dallas Morning News, shows RCA 12-Section Superturnstile Antenna of WFAA-TV being mounted.

RIGHT—"Straight as an arrow," Hill Tower soars into the skies with its RCA "Candelabra" antenna system—Ready for Operation.

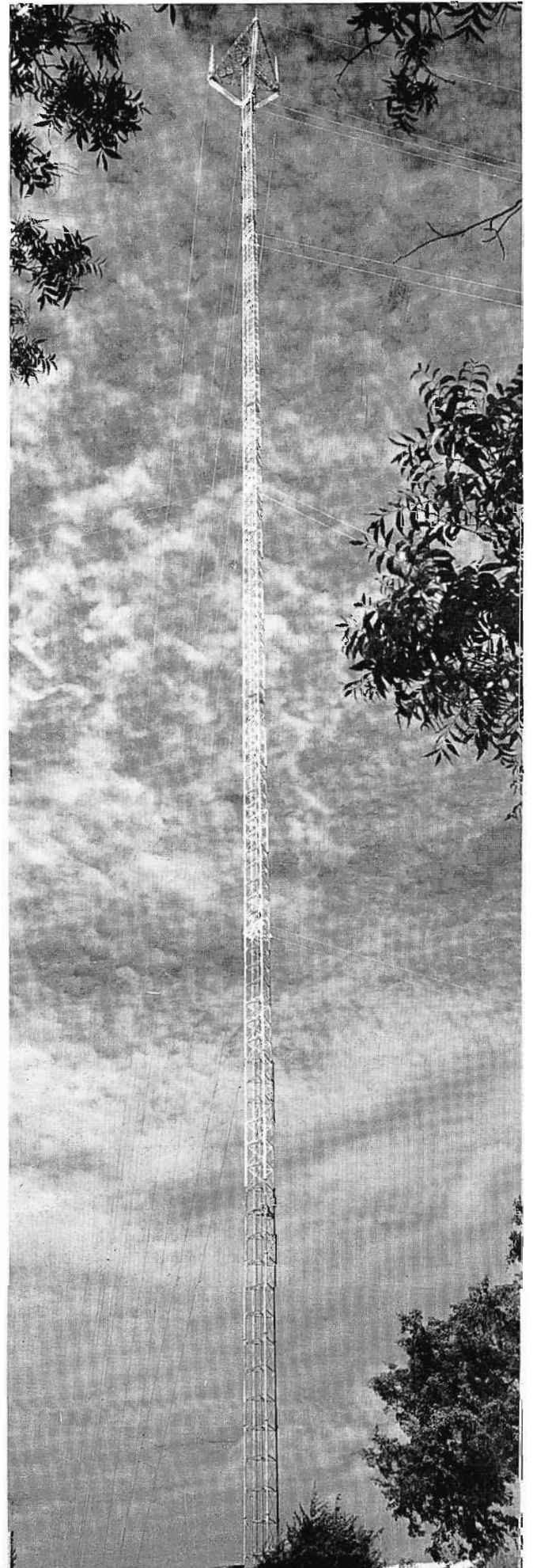

The lobby entrance to WLDB studios on the eleventh floor of the Atlantic City Senator Hotel is inviting and comfortably appointed.

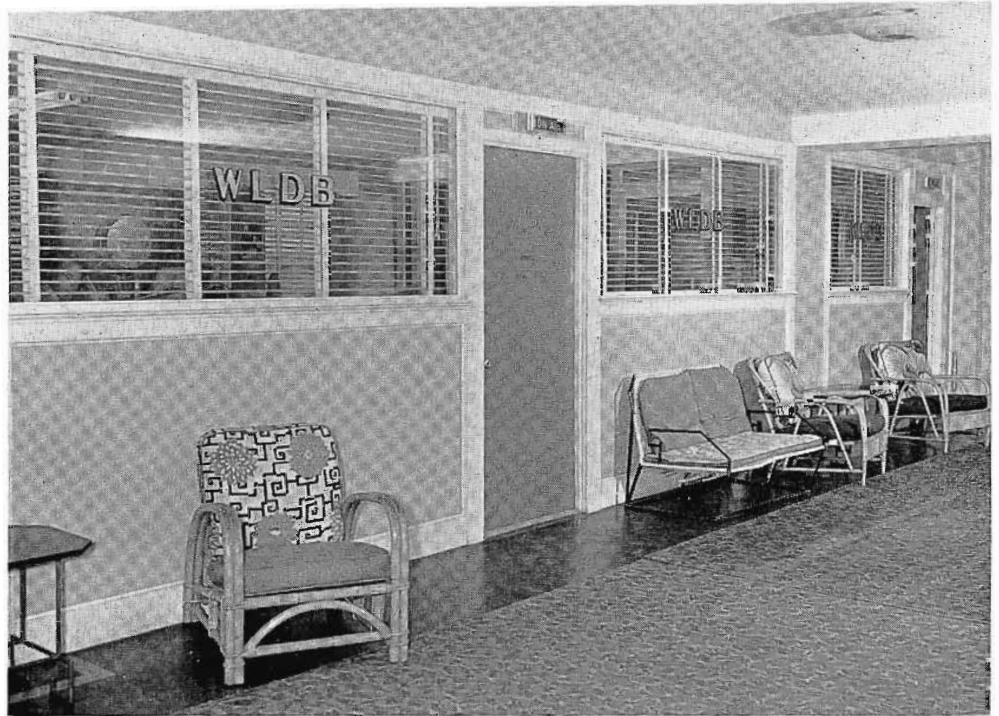

WLDB

ATLANTIC CITY'S NEWEST RADIO VOICE... REMOTE CONTROLLED

Atlantic City, New Jersey has a new radio voice—WLDB—owned and operated by Leroy and Dorothy Bremmer. The station is a fine example of progressive station management and planning, combining the best in technical equipment with efficient, close-knit teamwork.

Efficiency of operation is the keynote at WLDB. The studios, located on the eleventh floor of the Senator Hotel, one of the area's largest and best known hotels, overlook the city and the world-famed beach

area. From the windows, a million dollar panorama of the "World's Playground" meets the eye. The transmitting facilities are located on the edge of the city, in a less-congested area, and are operated entirely by remote control by means of the RCA BTR-5A Remote Control Equipment. This equipment, installed on the RCA BTA-250M transmitter, permits studio personnel to supervise the transmitter operation continuously as well as providing the necessary control facilities.

THE STUDIOS

The WLDB studios are designed for "finger-tip" efficiency. Excellent planning has provided a control and studio layout which lends itself to simple, straightforward operation with a minimum of complication. Three turntables are used, two RCA BQ-2A three-speed 16-inch turntables and, as an auxiliary unit, an RCA BQ-1A two-speed turntable. The smaller BQ-1A turntable is in regular use for recorded jingles, spots and themes.

John F. Moore, Station Manager, demonstrates operation of RCA RT-11B tape programming equipment.



Ken Mendelsohn, announcer "on mike" is surrounded with the finest RCA studio equipment.



Left to right: Mrs. Dorothy Bremmer and LeRoy Bremmer, station owners, with John Moore, Station Manager.

The use of the full-size RCA BC-2B Consolette permits maximum flexibility of operation, in that a full range of facilities is available to the operator. The ease of operation inherent in the design of the BC-2B is important, says Mr. Bremmer, since the announcer operates the control board during most of the operating day. The RCA RT-11B professional tape recorder is located directly to the rear of the control position, which permits immediate access by the announcer or engineer, who may change tapes without leaving the control board. The station makes considerable use of tape recording, and also has available a PT6-JAH portable recorder which is used for field interviews, re-broadcasts and the like.

PROGRAMMING PHILOSOPHY

Although Atlantic City is thought of primarily as a resort city, WLDB is not programmed as a "resort-town" station. Instead, Mr. and Mrs. Bremmer have planned a type of program schedule which appeals to visitors and permanent residents alike. Instead of featuring "pop" tunes, or classical selections, or any other single type program, a well-balanced selection of musical fare, augmented by a judicious choice of local and national news, sports, and public interest features presents WLDB's listeners with year-'round entertainment. The program policy is intended to build a loyal audience which will continue to listen with interest throughout the day and evening, rather than tune from station to station in search of variety. "Block Programming" techniques are used, supplemented by a selection of programs from the Mutual Network.

(CENTER): William Stringer, Jr. cues Dave Van Sant for news cast on RCA 44BX mike.

(RIGHT): Dick Brewer gives the commercial on RCA 77-D mike with control at BC-2B Consolette.



THE TRANSMITTER AND ANTENNA SYSTEM

The transmitter is housed in a small, simple cinder block structure some thirty feet from the base of the 150-foot guyed, insulated tower. The tower base rests upon a 65-foot wooden piling sunk into the sand. This is, according to the Bremmers, the only guyed-type broadcast tower in Atlantic City, and represents a considerable engineering advance over previous techniques. It had been considered to be essential that self-supporting towers be used in Atlantic City due to the soft, sandy foundation soil typical of Absecon Island, upon which Atlantic City is located. The tower, which was designed and erected by Stainless Inc. of North Wales, Pennsylvania, is so constructed that an additional 100-foot section may be added at a future date, which would provide a 250-foot radiating structure. An excellent ground-radial system of all-new No. 10 copper wire in conjunction with the radiating structure provides more-than-adequate signal strength — reaching distant communities.

A DEPENDABLE REMOTE-CONTROL SYSTEM

The BTR-5A Remote Control Equipment in use at WLDB permits the entire transmitter installation to be supervised and operated from the studio site, with only occasional visits to the transmitter building for routine maintenance. At the transmitter site the control portion of the BTR-5A installation is located in a cabinet rack which stands next to the BTA-250M transmitter, while the various actuators, meter shunts, relays and so forth are mounted on the transmitter itself. For ease of operation and maintenance the frequency and modulation monitors were permitted to remain at the transmitter site, thereby making them readily available to the Chief Engineer when he visits the transmitter for routine maintenance. The meter readings of the monitors are transferred to the studio through two of the BTR-5A circuits.

The BTR-5A permits the operator to read the transmitter plate voltage, plate current, antenna current and filament voltage, in addition to the previously-mentioned monitor readings. In addition, one circuit is available to indicate the current

Remote-control transmitter house and Stainless guyed tower. Tower is insulated at base and is approximately a quarter-wave length on 1490 kilocycles.

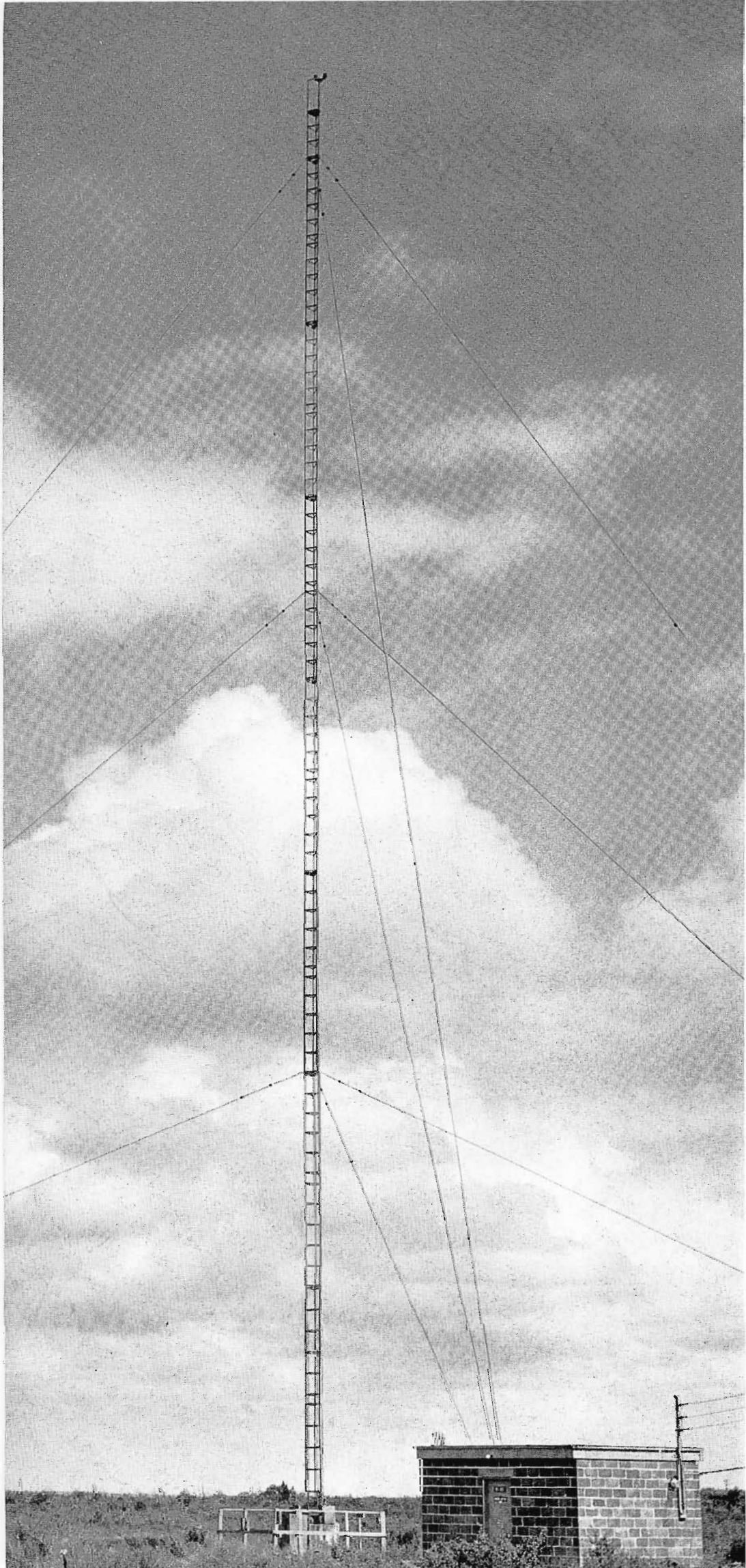

in the tower lighting circuit. The operator can control the tower lights, transmitter a-c power, filament voltage, and plate voltage, and can also reset the circuit breakers in the transmitter. The d-c control and metering circuits require only two low-cost control lines to the transmitter site, and the installation is impervious to sudden surges of voltage in the lines caused by lightning or static discharges. The WLDB tower has been struck by lightning several times without any loss of air time, and

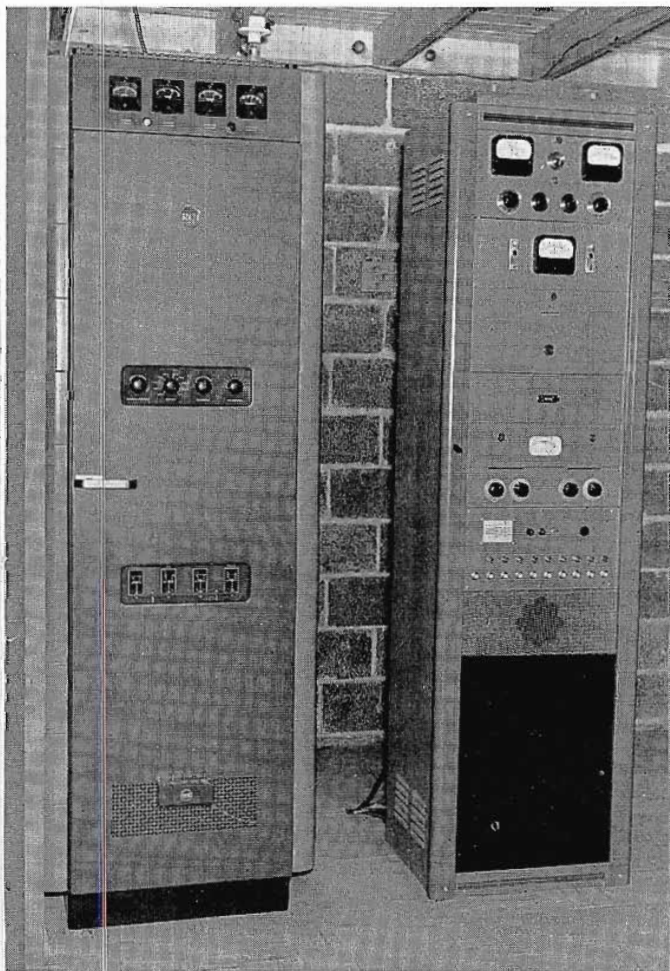

RCA BTA-250M, 250 watt transmitter (left) with RCA BTR-5A remote-control rack (right) constitute the unattended remote-control equipment.

without affecting the remote control installation in any way. On one occasion, WLDB was the only station in Atlantic City to remain on the air during a severe storm. According to the Bremmers the BTR-5A installation, in conjunction with the equipment it controls, has proven itself completely and they rely on it to the full extent. WLDB has set an interesting style with its efficient remote-control Radio Broadcast facilities.

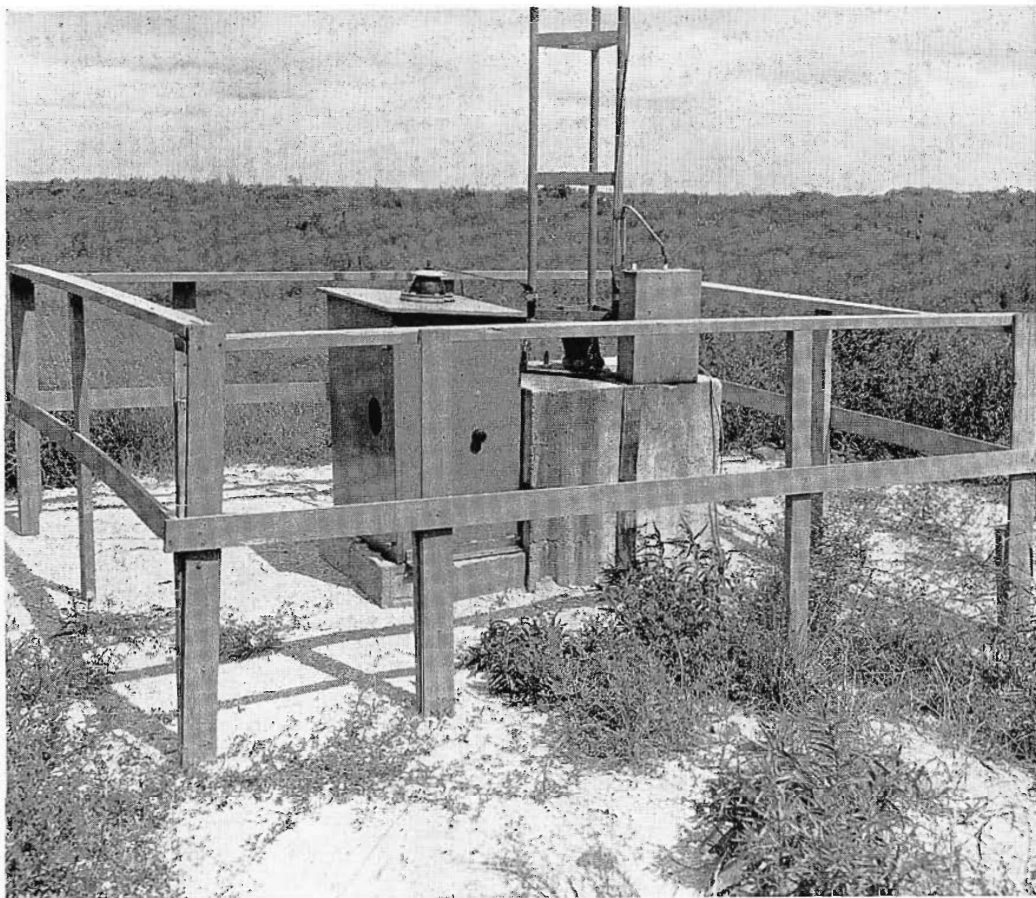

Base of tower with line terminating unit (left) and tower lighting choke (right).

Remote transmitter building 12'x18'x8' showing power lines and remote telephone line entering the simple cinder-block structure.

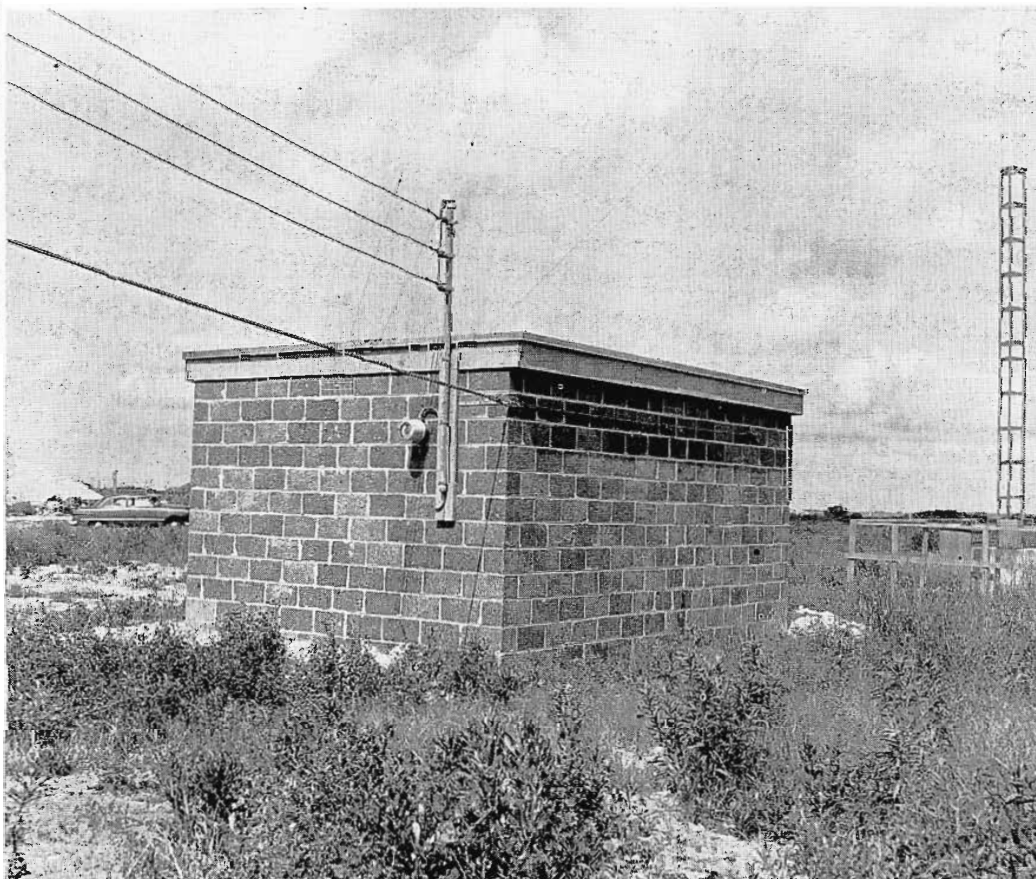



OPERATION CUE. Observers watch as explosion two times more powerful than Hiroshima is set-off at the Atomic Energy Commission's Nevada Test Site.



BROADCAST AND COMMUNICATIONS EQUIPMENT WITHSTANDS ATOMIC BLAST

Though The Blast Was Equal To Two Hiroshimas, Exploded A Deep Freezer And Blew Down A Brick House, RCA Equipment Came Through Unscathed. This Experience Shows How Location Of Equipment And Proper Shielding, Using Reinforced Partitions, Can Play An Important Part In Preventing Damage.

**Prepared by E. C. BILL¹
from reports by
R. W. PEARSON²
and
J. E. YOUNG³**

What will happen to your broadcast or communications equipment if an atom bomb hits less than a mile away? This is what R. W. Pearson, one of RCA's observers at precisely such an event, reports:

"Finally, at 5:10 a.m. Pacific Daylight Time (about ½ hour before sunup) on May 5 the blast was set off—a more awe-inspiring, horrifyingly beautiful sight is seldom seen. (We witnessed the blast from the AEC's Control Point seven and one-half miles distant. About 1500 Civil Defense people were here also.)"

About 7:00 a.m., RCA's Jack Young, together with Ray Williamson (RETMA Project Officer), specially clothed, and properly dosimetered, film badged, and respirated, followed the AEC radio activity measuring team into the blast area. They reconnoitered the many buildings to see what had happened to the electronic equipment. At 12:30 p.m. Jack and Ray emerged from the area and reported the following to the other 12 members of the RETMA team:

- (a) The 250-watt AM transmitter and gear appeared undamaged but the pole power lines were blown down, hence no power available to bring the radio back on the air three minutes after the blast as scheduled.
- (b) The car at the 4700-foot line was badly damaged, but the two-way radio appeared undamaged.
- (c) The base station transmitter was blown out of the second story bathroom, and ended up in the ground floor rubble, upside down, and severely dented.

"We arrived in the blast area at 1:10 p.m. By 1:25 p.m. we had strung some wires (clipped from the poles) along the ground between the transmitter and to the generator, then started the gas engine. About one minute later the 250-watt transmitter was *back on the air!* No tubes broken. No meters damaged. Even the continuous tape in the tape recorder was undamaged. (One of the partitions in the house shielded the transmitter from the flying glass, flying venetian blind slats, flying window casements, and from other flying debris.) The studio console and oscilloscope were on a table and took the full force of the blast with no shielding from any partitions. We found these items on the concrete floor. The console was banged up from the fall, its top and bottom covers blasted open, but it was operating.

"After digging the mobile radio base station out of the rubble (all that was left of the two-story brick house) and working it against the mobile unit (gotten to by crowbarring off the back of the automobile), communications were established loud and clear.

"Over 100 newspaper owners (most of them own radio stations as well) witnessed the RCA station going back on the air in the area where houses were blown to bits. That is bound to leave an impression. We spoke to dozens of these newspapermen after the blast, and they were astounded that the transmitter tubes would even light up, much less send out an intelligible signal."

Shelters Can Be Lifesavers

What will happen to *you* if you are with your equipment when the bomb goes off? If you have no warning, you'll probably not survive. But if you do have warning, as there are long odds that you will, your chances may not be too bad, in the light of Pearson's observations concerning shelters:

"The simplest and cheapest of shelters, if properly located and built can prevent injury to human beings even at the 4700-

¹ Engineering Products Advertising Dept.
² Products Planning, Engineering Products Division.
³ RCA Broadcast Transmitter Engineering.

Aerial view of test site showing radio building at right, and 150-foot guyed antenna.





▲
BEFORE. This is the transmitter room before the blast.

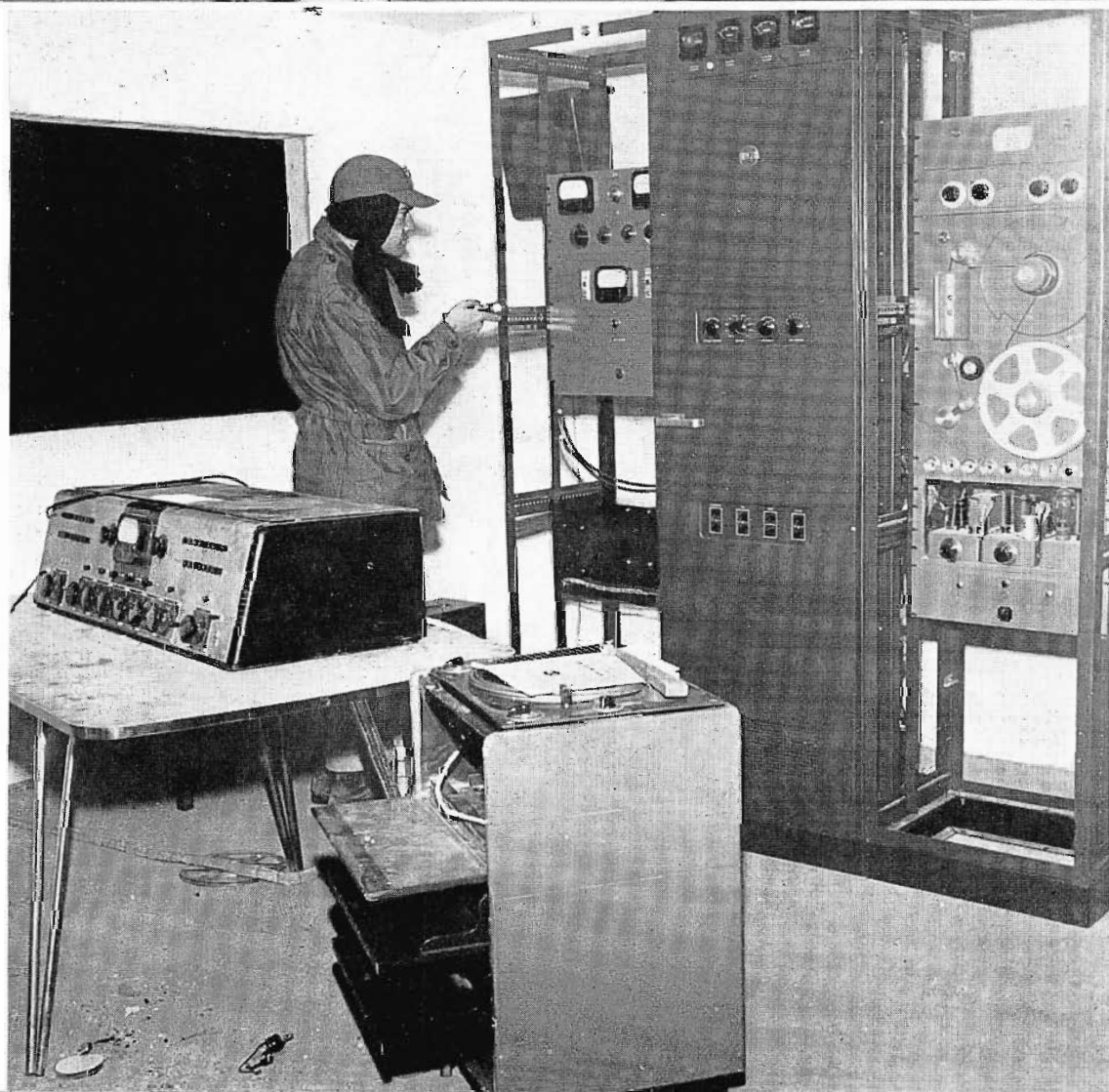

▶
AFTER. This is the transmitter room after the blast—the mannequins were blown out of view beyond the carried-away window.

foot line. The two-story brick building was completely demolished into a pile of rubble, but a simple 2 x 12-inch plank lean-to, in the cellar and *bolted* to the floor and wall, protected *everything* within the shelter. Likewise, an 8-foot square shelter in the basement, made of 1/8-inch corrugated steel, *bolted* to upright posts, and *bolted* to a corrugated steel ceiling sheet protected everything inside. (Have the corrugated sheets completely enclose the shelter—do *not* have one or two cellar foundation walls as part of the shelter.) The shelters will protect one from radiation and from flying or falling debris, and will partially protect against the intense heat even at the 4700-foot line.”

Report on Commercial Equipment

The foregoing is the essence of Bob Pearson’s summary report. We reprint below portions of the complete statement prepared by him and J. E. Young, RCA Broadcast Transmitter Engineer.

“Early last Fall the Federal Civil Defense Administration (FCDA) requested the Radio-Electronics and Television Manufacturers Association (RETMA) to participate with 14 other national trade associations in an atomic ‘open’ shot program then being arranged through the Atomic Energy Commission (AEC) to take place at the Nevada Test Site, Mercury, Nevada, early in 1955. The purpose of the entire program was two-fold: (1) to impress upon the average American the horribly devastating effects of atomic weapons on populated areas, and (2) to obtain atomic blast information on many kinds of commercial equipments, structures, homes, etc.

RCA Equipped AM Station and Mobile Communications Setup

“RCA’s contribution to this Civil Defense experiment was the services of several engineers plus one each of the following equipments to set up and operate a complete 250-watt AM broadcast station with studio gear:

- BTA-250M Transmitter
- 76-B-2 Consolette
- BW-11A Frequency Monitor
- BW-66E Modulation Monitor
- BQ-1A Turntable
- RT-11B Tape Recorder
- BA-6A Limiting Amplifier
- SK-46 Desk Microphone
- 10 inch. Speaker and Cabinet

In addition, a two-car and base station two-way communications system was provided, consisting of:

- 1 CSF-60A 60-watt Base Station
- 2 CMV-2E3 30-watt Mobile Units
- 1 CA-1A Base Station Antenna

“An RCA 5-inch Oscilloscope was also in the test. All equipments were brand new, (except the AM Consolette) taken from stock, with no additional or special tests of any kind. All of this equipment was in first class operating condition at the time of the blast, thanks to the magnificent work of Howard Shinn and Roy Johnson of the RCA Service Company, Government Division office in San Francisco. Several RETMA-member companies provided components, wire, coaxial cable, antennas and towers which were utilized by RCA as part of the overall project.

RETMA Objectives

“With the preliminary planning work completed, RETMA appointed Ray Williamson of General Electric, and Jack Young of RCA as Project Officer and Assistant Project Officer respectively, and charged them with the successful accomplishment of RETMA’s mission:

- (a) Find out the effects of an atomic blast on commercial electronic equipments,
- (b) Evaluate the damage done to the equipments and estimate the time required to get them back into operation. Operate those that will operate.
- (c) Get the AM transmitter back on the air if it appears feasible to do so in a reasonable time.

“The full import of this charge did not dawn on us until about five days before D-day when Al Stevenson, FCDA Technical Advisor, called Bob Pearson from the Nevada Test site and frantically pleaded, ‘Bob, for gosh sakes, put your AM transmitter back at the 10,500-foot line!—If you don’t you’ll be picking it up in pieces! You have no idea how badly the buildings and equipments will be damaged at the 4700-foot line!’ We gave serious consideration to this suggestion, but we decided to continue with our previous plan—that of placing the equipment as close to ground zero as we could get it housed, then evaluating the blast damage on it as cold-bloodedly as we could. (We’ll have to admit that this decision seemed mighty weak after we got out to the AEC’s Nevada Test Site and saw the awful destruction left in the wake of other A-blasts, but decision it was, and we let it stand.)

“We’ll bet that the RCA Service Company never received a request like this one:

‘Please purchase two jalopies in or around the San Francisco area, install and make operable the mobile equipments, and drive (or otherwise get) the jalopies to the Nevada Test Site prior to March 1, 1955.’

“This was done—a 1941 Plymouth and a 1937 Cadillac, no less.

Camp Mercury Test Site

“The Army’s Camp Mercury Weather Station at the test site is probably one of the best equipped, best manned in the world. Nevertheless, it sure took an ear beating by all of us each day the shot was postponed. But when the shot did get off, and we saw that the atomic cloud drifted exactly where the scientists wanted it, our faith in meteorologists was more than restored. We would like to be able to predict the exact movements of eight or ten different layers of air up to 45,000 feet altitude.

This is why the power failed. As soon as power could be restored, the transmitter went on-air.

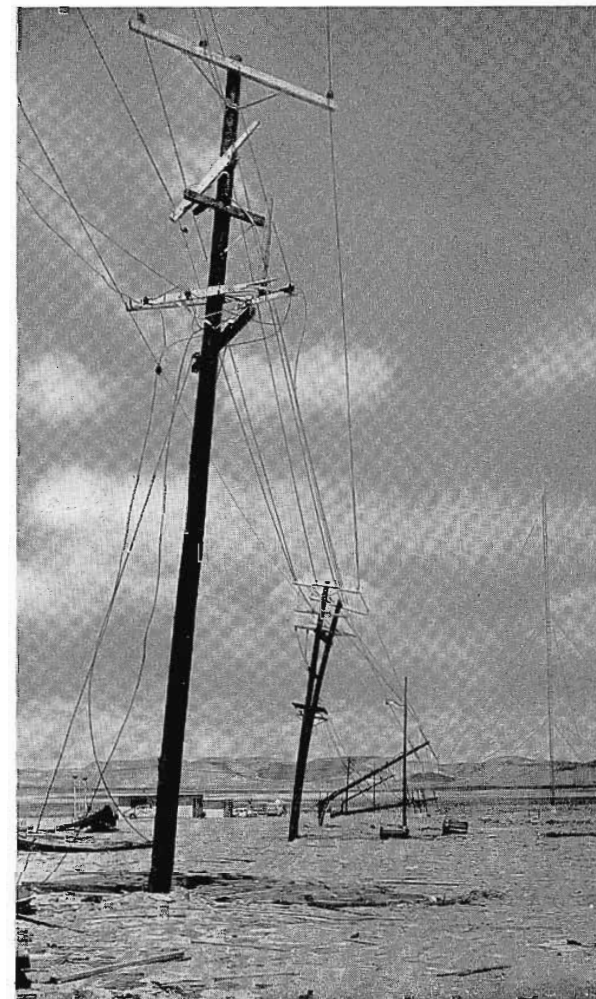



Frame house after the blast—the building was completely demolished.

“About two miles away was the U. S. Army’s ‘Camp Desert Rock’, the home of the world’s most fearless soldiers—the atomic fireball had hardly died away before these boys were grinding forward in their tanks, helicopters and armored vehicles. The tanks, fully manned, were only about 3000 feet from ground zero at the time of detonation, but onward they went, guided, we’ll bet, by some stunned and dazed soldiers.

Broadcast Equipment Installed in Block House

“As D-day approached, the installation work got feverishly underway. RCA’s 250-watt AM transmitter was housed in an expanded shale block, reinforced concrete roof, concrete slab base, ranch-type house. The construction was somewhat improved over the ordinary concrete block house, for here the steel rods in the concrete slab roof were welded to 3-inch upright pipe

posts in the corners of the buildings. The bottom ends of these pipes were also welded to the reinforcing rods in the concrete base slab. Thus the roof was mechanically connected to the base. Since the concrete slab roof was about 5 or 6 inches thick, it wasn’t without mass—an important observation, because inertia plays a mighty important part in whether or not a structure stays together during an A-blast. A concrete block wall in the house shielded the transmitter from ground zero. The 150-foot guyed antenna by Stainless, Inc., was ready. We ran some RG/17U coax from the transmitter to the antenna. Some of it was a few inches underground, some on the surface, to see what effect pressure and heat would have on it.

“Approximately twenty 100-foot No. 10 copper wire radials from the antenna base formed the ground plane (moist earth was probably 40 to 80 feet down, and we couldn’t depend on it). Power lines from the building to a utility pole line across the street were installed. The pole line was fed by an AEC-supplied gasoline engine driven generator in a ditch, 4 or 5 feet deep behind the house next to us (about 100 feet away). Picture this set-up in your mind, because it was this pole line that prevented us from getting back on the air immediately after the blast.

“RCA’s console, in full operation, was on a table in front of the transmitter. The turntable was beside this table. There was nothing between ground zero and these items except a steel framed casement window—and venetian blind. On this same table was the RCA 5-inch oscilloscope.

Brick house after the blast—this building was likewise demolished.

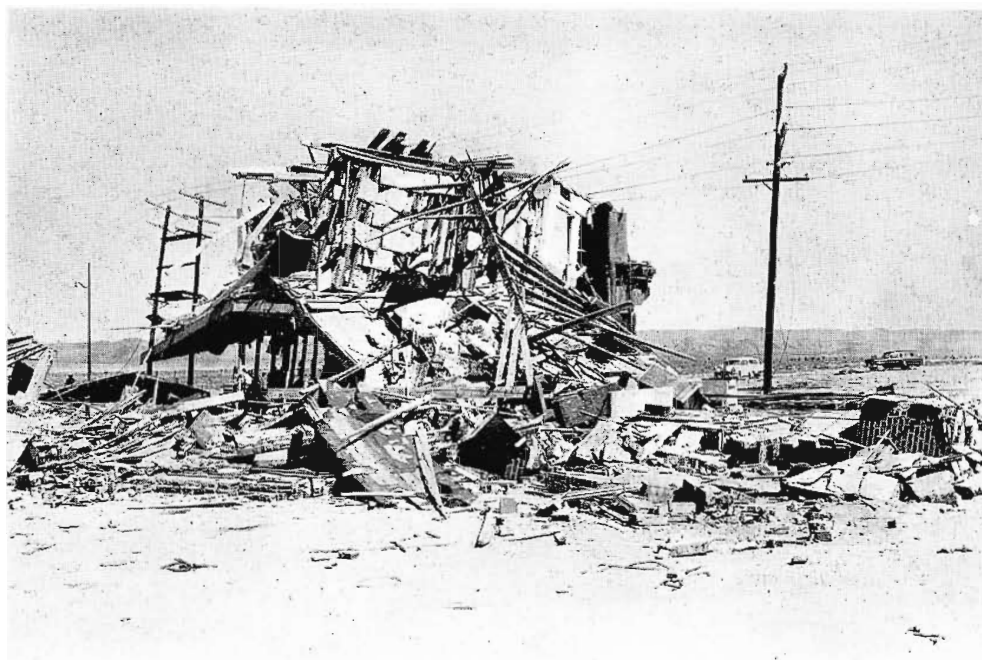

D-Day Approaches

“D-day was Tuesday, April 26. On Saturday the 23rd we went into Las Vegas to get FCDA’s speech recorded. Who did we find to record it? A radio announcer from Boston—a small world, isn’t it? He provided us with a 3¼ minute talk on what the test was all about, then 2 minutes of silence. This was repeated over and over again while the transmitter was on the air.

“In the meantime, our jalopies were placed in position. The Plymouth alongside the 250-watt transmitter building, at the 4700-foot line, and the Cadillac beside a similar house on the 10,500-foot line. The base station was installed in the second floor bathroom of a two-story brick veneered concrete block building on the 4700-foot line, but about 300 feet from the 250-watt transmitter building. The base station was hooked up to our antenna on a 100-foot fixed tower about 100 feet across the street. We tested out the base

station and mobile units loud and clear at 35.5 mc.

“We were ready. But Mother Nature had other ideas. The storm center which was supposed to pass through the Test Site on D-2, didn’t get there until late on D-1. That meant the winds would be wrong, and if the blast went off we’d cover Las Vegas with some radioactive fall-out. (Of course it wouldn’t harm anyone, because everyone would be inside feeding coins to those one-armed bandits.)

“Each morning at 10:30 a.m. the AEC Test Director and his staff would meet in the Meteorological Building at Camp Mercury to see if they could predict the whims of Mother Nature. If it looked favorable (as it did six times in the next nine days) the Test Director would declare the shot ON for the next morning. This was signified by the lighting of a flashing blue light high on a pole in the Camp Mercury area. This scientific group would then meet again at 9:30 p.m. to review the situation. Meteorological reports came up from stations just a few miles away, and from stations way out to sea, or up in Canada and Alaska. If these reports, interpreted and plotted on the weather map, were favorable, the blue light continued to flash. If unfavorable, the blue light changed to flashing red (and so did some of our tempers). If this 9:30 p.m. weather briefing looked favorable, dozens and dozens of scientists and engineers would start out to get to their lookout and instrument stations,—some as far away as 150 miles. Jack would drive 35 miles to the test site and put the transmitter on the air with its repeat tape program.

D-Day

“D-day finally arrived on May 5th, and H-hour at 5:10 a.m., Pacific Daylight Saving Time (about one-half hour before sun-up). We looked around us. Whereas 5000 people came out to this hill on April 27th, there were only about 1500 out this morning. The others couldn’t wait out the delays, or they lost all their money to the one-armed bandits in Las Vegas and had to go home. (Western Union did a land office business—‘Blast delayed. Wire me some money at once!’) The PA system carried the recorded message from the AM transmitter. It was working very well.

“The announcer said: ‘It’s H minus one minute, those with dark glasses put them in place. The others will turn their backs to *Ground Zero* and close your eyes tight—30 seconds—15 seconds—10, 9, 8, 7, 6,—(Darn it, I’m all thumbs)—3, 2, 1.’—Two or three seconds later I opened my eyes—

just a trifle and the reflection of the light from the ground was five to seven times that of the noon-day sun. Incredible but true. The white hot fire-ball was boiling outward and upward, changing color to bright cherry, to red, to brown. That was the Atomic Cloud. A few moments later the stem of the cloud flared up into a brilliant blue as the effects of ionization became visible. The cloud rose rapidly. Probably to 20,000 feet in the first minute, and to 40,000 by the fourth minute. It started to drift eastward, the top at a much, much faster rate than the bottom. That fireball should have lasted longer than it did. We’d swear it was for only six or seven seconds.

“*Look!* The clouds at the base of the mushroom were churning up like a hurricane, and expanding in all directions across the desert. Let’s get a picture of that drone going into the cloud! There’s another! Look at—C R A C K ! ! ! Wow! That was the shock wave, and did it startle us? Just like the thunder clap following a bolt of lightning hitting the telephone pole across the street. We had calculated that it should

get to us seven and one-half miles away from ground zero) in about 30 to 50 seconds. It actually seemed more like half that long. We must have lost track of time.

“Everyone seemed taken by surprise. Some folks said you could see it coming across the desert kicking up the dust before it. We weren’t fortunate enough to observe that.

“The PA announcer said: ‘We can’t get any signal from the AM transmitter.’ We wondered, did the walls of the building blow out and the roof cave in? Well, we’d have to wait to see.

“The cloud rose higher and higher, its top drifting farther and farther to the east. Reports from jet planes indicated that the top of the cloud was at 42,000 feet where the high velocity winds moved it eastward faster than it could rise higher. It was a rusty brown in color. It reminded one of rusty tin-can dust. At about 7:00 a.m. Jack Young and Ray Williamson put on their special coveralls, booties, and turbans, secured the edges with 2-inch masking tape,

Concrete block house after the blast—TV antenna is down, windows are blown out, car is badly damaged, mahogany doors became toothpicks, but the house stood up—so did the transmitter.



put on their respirators and headed into the blast area. They were preceded by a dozen radiologists who, with mobile radio equipments, Geiger counters and other measuring equipment, started into the area about 6 or 6:30 a.m. to a series of pre-arranged points where radio-activity reports were radioed into the Control Point:

Station 301.2, 25 mr (milli-Roentgens); Station 402.3, 100 mr.; Station 301.3, 30 mr, etc.

In about one-half hour the degree of radioactivity was beautifully contoured on maps of the blast site.

Reports Were Unbelievable

"The morning dawdled on. At 12:30 p.m. Ray and Jack emerged. It took us about 15 minutes to get the truth out of them. We couldn't believe their stories. It seemed too incredible. The rest of us arrived at the blast site at 1:10 p.m. It *was* incredible. Roy, Howard and Bob surveyed the situation. The power lines had been blown down, thus separating the house

lead-in wires to the transmitter. A couple of swipes with the pliers and the poles were minus some wires. A few shaves with the pocketknife, a few twists of the wrists, then a tape job, and we had two leads from the transmitter, along the ground to the gas generator. Roy pushed the START button at the generator. It started up. This took us less than 15 minutes. A quick look at the 150-foot guyed antenna. It was still up, but bowed. We attributed the bow to the fact that the pole lines had fallen on the guy wires thus adding more guying force to some guys than to others. We hurried back into the transmitter room. No broken tubes. No broken meter glasses. In fact, the tube filaments were lit. (Hadn't we just started the generator?) The plate circuit time delay relay was clicking away. The console was lying on the floor, top and bottom wide open on their hinges. All tube filaments were lit. The DB meter light was on. The tape on the tape recorder was moving. No tubes broken in the amplifiers. The frequency monitor unit was operating. (The deviation from 1240 kc was even less

than before the blast.) The modulation monitor meters and tubes were lit up. Then, the 12-inch speaker blared forth: 'This is station KX2MO'—We glanced at the plate meter. YES, we were on the air.

"The room was a shambles. Mannequin pieces all over the floor. Kiddie mannequins slammed up against the wall. The RCA oscilloscope thrown in a corner, right side up. Some kind of shrunken up metal wrapped around wires, table legs, microphones, camera stands, etc. What *was* the stuff anyway? Then it dawned on us. This was what was left of the venetian blinds. They had started to melt.

"All windows but two were blown to smithereens. The casement frames were blown into all kinds of grotesque shapes and some were blown out altogether. Powdered glass was everywhere and in everything. A few expanded shale blocks in the ground zero side of the house were bowed in a couple of inches. A window post made of 2-inch pipe which was lag screwed to a concrete block, split the block in two. The

This shows the transmitter did not take the full force of the explosion. The force of the blast broke through the windows. A wall of concrete block protected the transmitter.

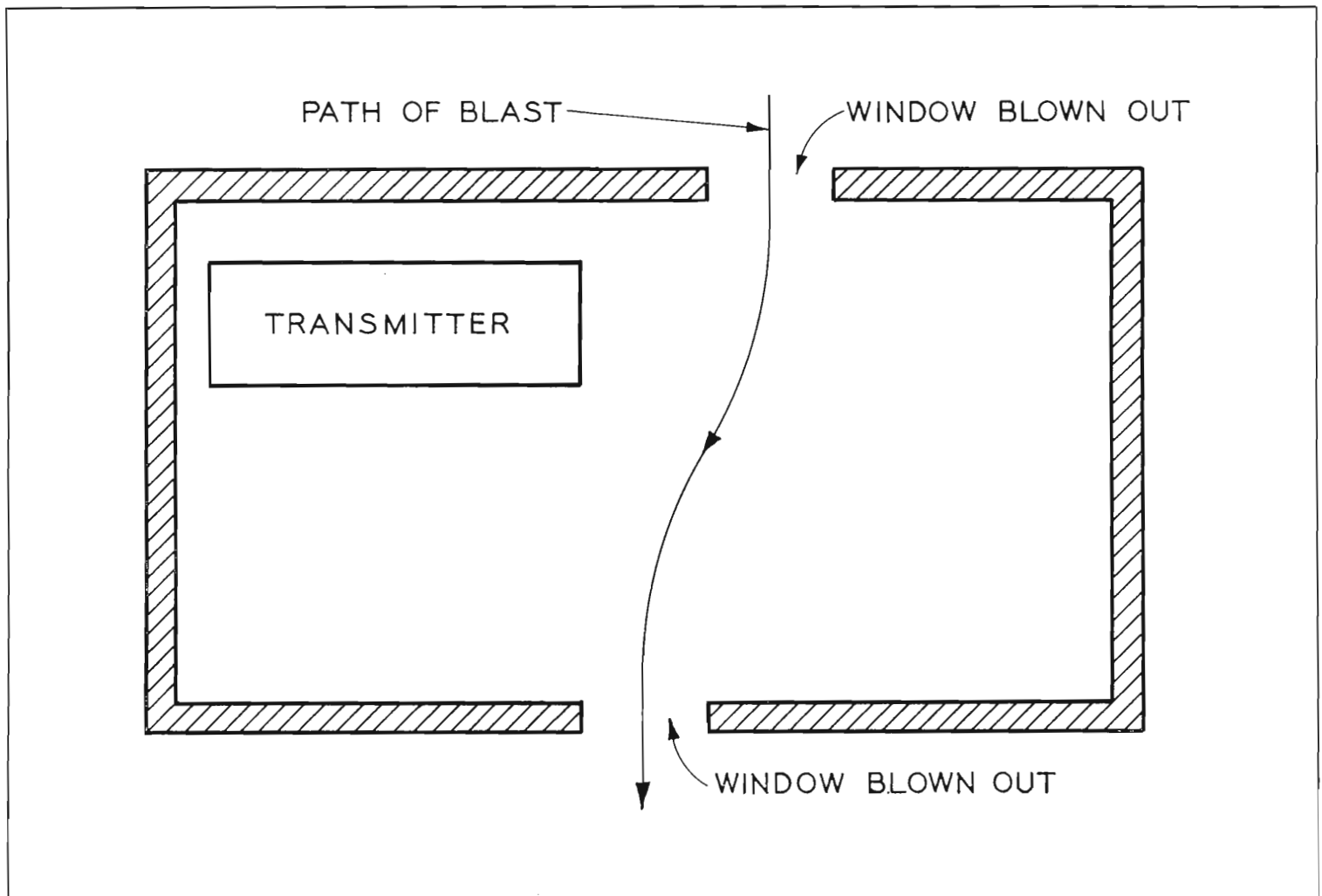

Phillipine Mahogany plywood doors had literally burst into small fragments, some the size of toothpicks. The door knobs were lying on the floor all battered up. The ceilings were scorched from the searing heat. The pole line wires and the RG/17U cable above ground had the outer insulation thoroughly cooked and blistered. The No. 10 bare copper wire in the ground-plane radials was scorched almost blue in some spots. But our AM transmitter was on the air for a total of more than eight hours on that afternoon and also on D-day plus one.

“Roy and Howard hurried over to the red brick house—more appropriately to the pile of debris which marked the spot. The house roof was 100 feet away. No brick walls were standing. Parts of the second floor were supported by a couple of 2 x 4 studs, waving in the breeze. The first floor joists were smashed in compression downward. But mannequins in the two shelters in the basement were okay. The boys started digging. They found the RCA mobile base station—half buried, upside down,

in the rubble. They applied 110 volts. Everything worked.

“The boys then used a hammer and crowbar to open up the Plymouth housing the RCA mobile unit. It’s roof was caved in and all windows were broken. They pried off the battered trunk cover. The mobile unit was dusty, but undamaged. In a couple of minutes two leads from Howard’s car battery were attached to the mobile power input terminals. With Roy at the base station and Howard at the mobile unit, communication was established. Loud and clear. No problems of any kind. Not even with the speaker or the microphone.

“Next we got some voltage to the RCA oscilloscope. It worked. And so our evaluation ended. Over a thousand newspaper men, Civil Defense people and scientists came to see the electronic equipment in operation after the blast.”

Essentially, that’s the end of Young’s and Pearson’s report. They observed, among other things not included in the

account above, that electronic equipment fared considerably better in the blast than buildings, heavy safes, trucks and house appliances such as refrigerators, freezers and stoves which most of us think of as pretty stoutly built.

Electronic Equipment Rugged; Easily Protected

What should we do to protect equipment from A-blast? Concrete walls help, and an absence of things like glass and venetian blinds which can turn into high-powered missiles. If a free path around the equipment can be provided for the blast wave, damage will undoubtedly be much reduced. One way of providing such a path is shown in the accompanying illustration. It is obviously not a good idea to park a car beside a brick chimney when the bombs are on the way. At such a moment probably nothing will seem like a very good idea, even that simple shelter in the basement. But it will be considerably better than no shelter at all, as the test has shown.

Here is one way of protecting equipment from damage. Leave a free path for the blast to follow and protect equipment with sturdily built partitions.

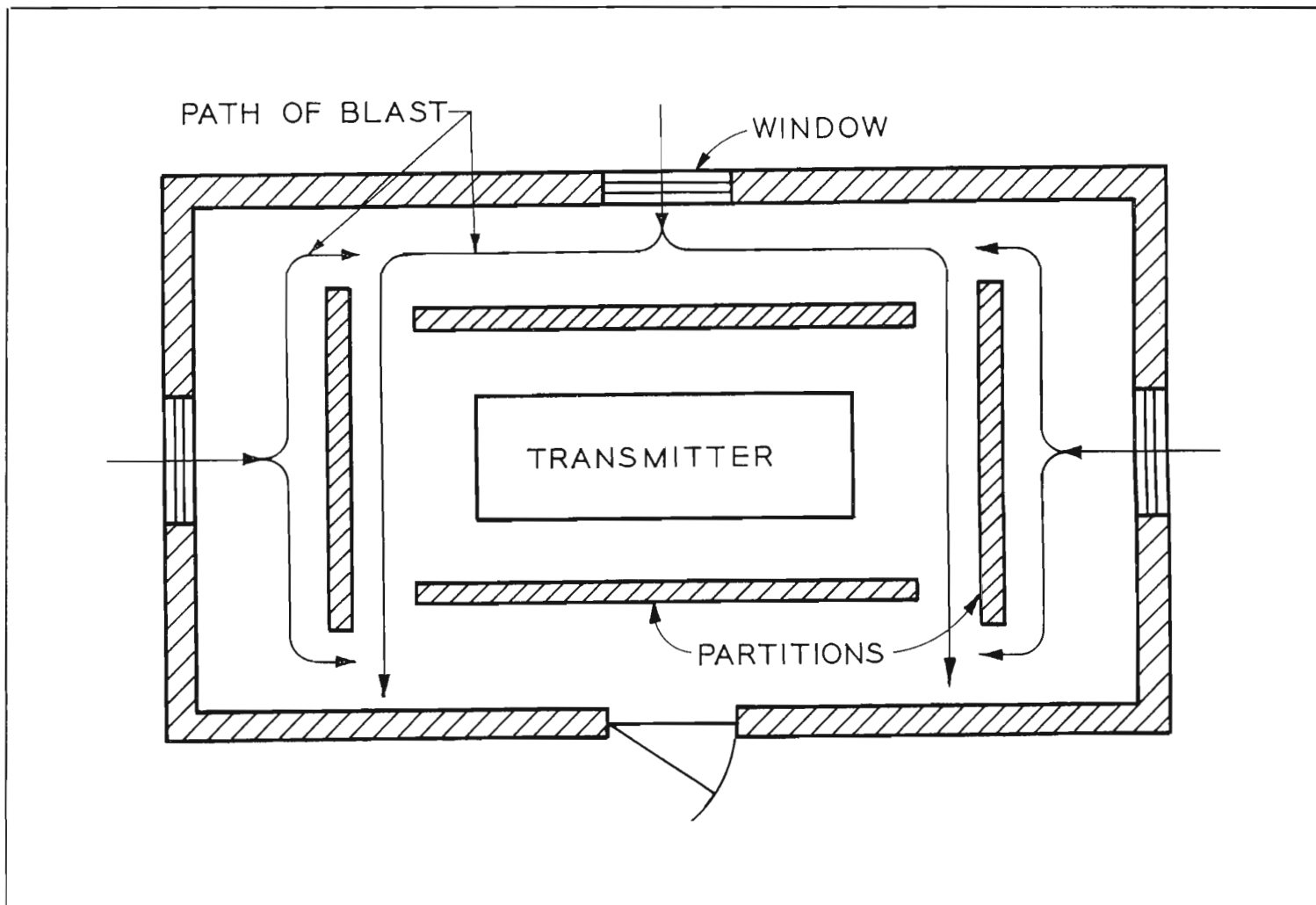

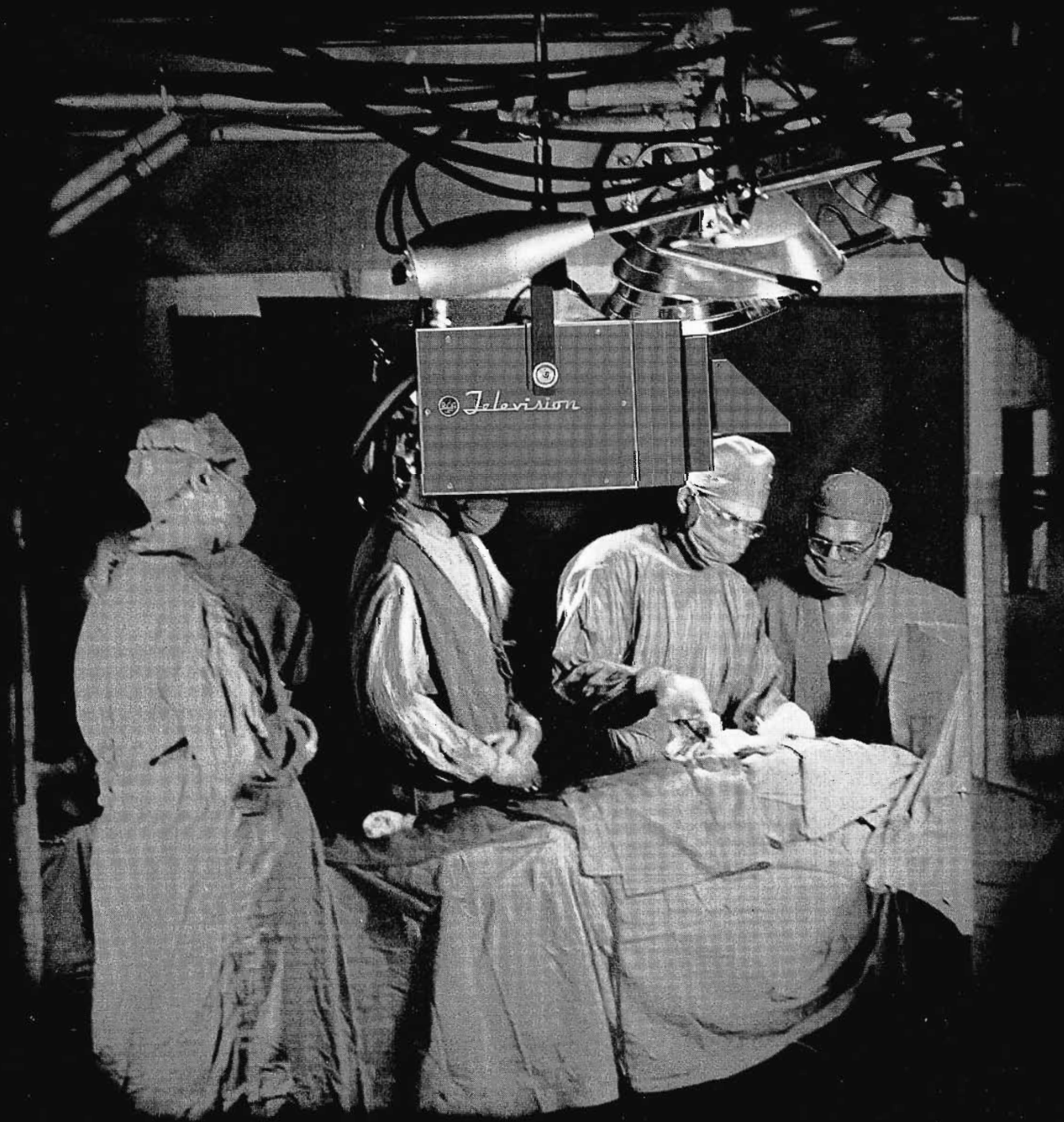

Surgery's New Teaching Tool

RCA DEMONSTRATES COLOR TV FOR MEDICAL USE

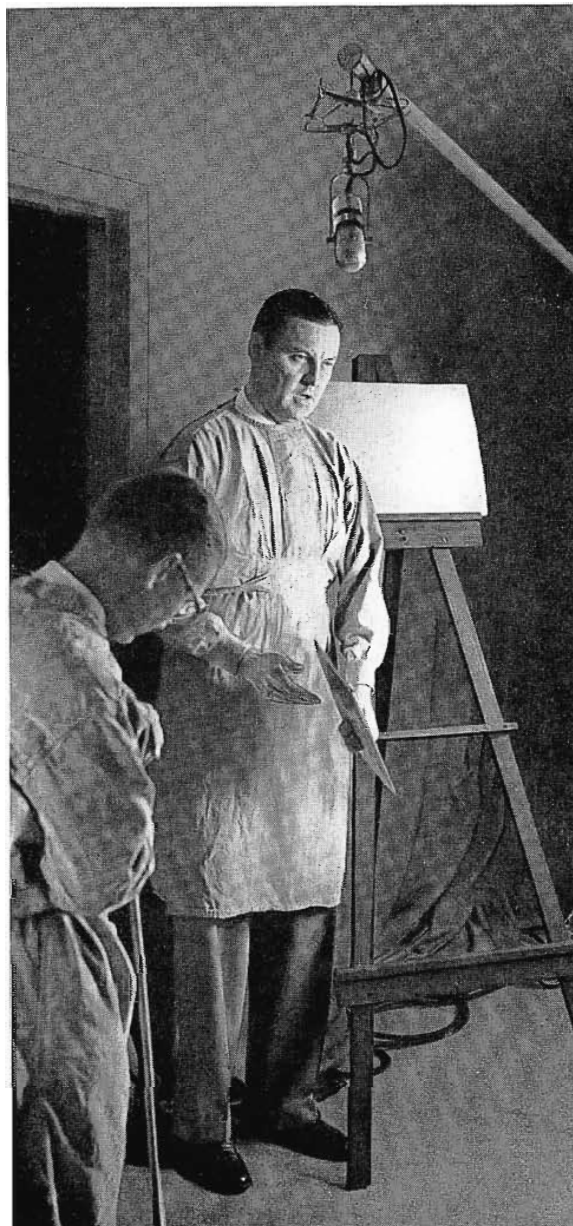

**New Technique in Teaching
Surgery and in Speeding
Medical Data to the Oper-
ating Room Shown to 1,000
at Annual Congress of
American and Canadian
Surgeons**

by E. T. GRIFFITH
Manager
Broadcast Customer Relations

RCA Color Television for medical use was demonstrated to more than 1000 American and Canadian surgeons at their 20th Annual Congress held in Philadelphia's Convention Hall. For thirty minutes the assembled surgeons watched a portion of an operation being performed at the Veterans Administration Hospital several blocks away.

DIAGNOSIS. Medical aspects of operation are described in detail using charts and diagrams —viewed on a TK-41 Live Color Camera.

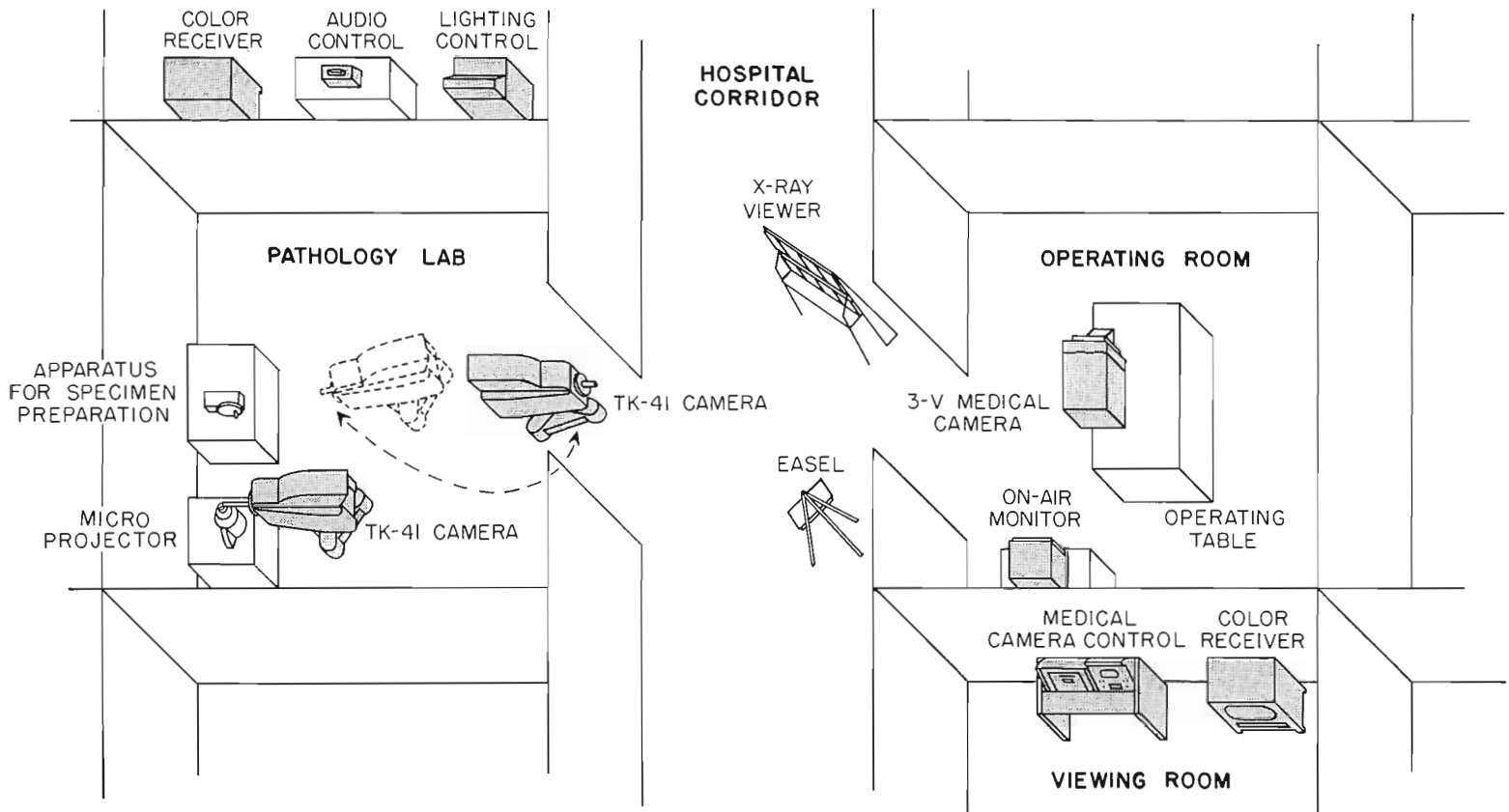

DEMONSTRATION LAYOUT. Sketch showing how equipment was used to colorcast the entire proceedings.

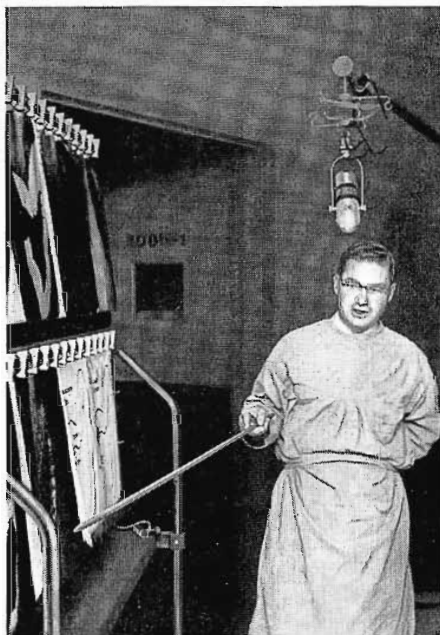

X-RAY DIAGNOSIS. Series of X-rays were placed on-camera to complete diagnosis.

The closed circuit presentation was arranged to visually demonstrate the use of Color Television in the exchange of medical information and for education in the medical field. Several phases were shown of an operation in which Dr. W. G. Nichols, the hospital's chief surgeon, removed an internal growth from a 64 year old male patient—a diagnosis was charted and explained by means of X-ray photographs, a microscopic view of a specimen removed from the patient was shown, and the doctor explained what procedures would be followed in view of the findings.

As a prelude to the demonstration, Dr. Alfred N. Goldsmith, New York television and electronics consultant, discussed in an address before the Congress of surgeons the growing importance of Color Television in the medical profession. He pictured a "super clinic" of the future where widely separated hospitals could be linked together by television, so that the expert knowledge of each could be available to all.

Medical 3-V Views Operation

The new 3-V Medical Color Camera was suspended above the operating table and focused on the operating area. Diagnosis and preparations were picked up on a standard TK-41 Color Studio Camera while another TK-41 was tied to a Bausch and Lomb Microprojector for specimen viewing. Camera cables were run from the 4th floor of the hospital, where the operation was performed, to an RCA Color Mobile Truck parked outside. The truck served as control room for the presentation. RCA color microwave equipment mounted on the hospital roof was used to relay the signal from the truck to Convention Hall where it was viewed on a 15 x 20-foot theatre-size color TV screen and several 21-inch color receivers.

A complete audio system was set up to handle the commentary accompanying the color pictures. A 77-D microphone on a boom stand was used to pick up the preliminary diagnosis and X-ray explanations.

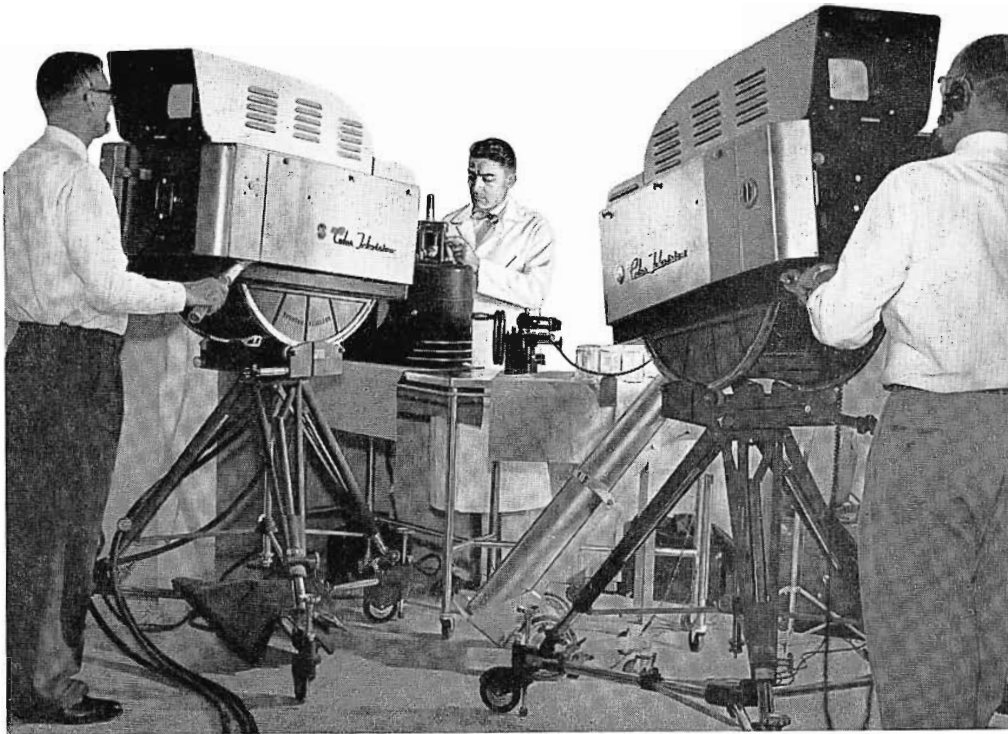

PATHOLOGY LAB. Two TK-41 Live Color Cameras were used here to pick up preparation and viewing of specimen slide.

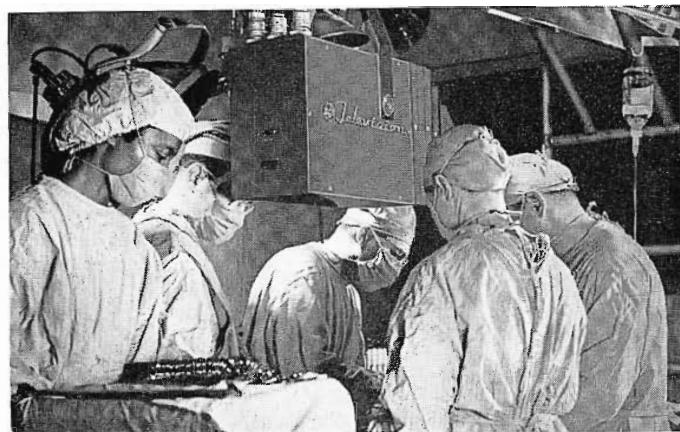

OPERATING ROOM. A tissue specimen is removed from the patient for biopsy.

Two BK-6A miniature mikes on lanyards were also used. One was concealed under the Chief Surgeon's scrub suit and the other was used by the Chief Pathologist in both the lab and the operating room. An RCA remote amplifier was used for audio control.

The diagram shown here outlines the equipment setup at the Veteran's Hospital. Through the cooperation and efforts of hospital officials, a special Pathology Laboratory was set up across the corridor from the 4th Floor Operating Room. It was from these two main areas plus the corridor in between that the program originated. Space was also made available for control positions and a viewing location.

The presentation opened on Dr. Henry P. Close, Chief of Medical Services, Veteran's Hospital. From his position in the corridor adjacent to the operating room, he described in detail the medical aspects of the case, using several charts and diagrams. He was followed by Dr. George Wohl, Chief Radiologist, Veteran's Hospital, who explained the diagnosis from six



BIOPSY. Slide of prepared and tested specimen is placed in microprojector and viewed by TK-41 Camera.

different X-ray pictures. Dr. Wohl then introduced Chief Surgeon Dr. W. G. Nichols who was in the operating room where the operation was already in progress. He gave a brief resume of what had taken place up to that moment. During this resume the 3-V Medical Camera viewed the area of surgery. Dr. Nichols removed a specimen from the patient and gave it to Chief Pathologist, Dr. Anthony Pietroluongo for biopsy.

The specimen was rushed across the hall to the Pathology Lab where Dr. Pietroluongo froze, sliced, and tested the specimen for malignancy. A slide of the specimen was prepared and placed in a Microprojector optically linked to a TK-41

Color Studio Camera. At the same time the specimen was being viewed in Convention Hall, it was being picked up on a monitor in the operating room for Dr. Nichols' examination. Dr. Nichols discussed the condition of the specimen with Dr. Pietroluongo who had returned to the operating room. Dr. Nichols summed up their findings and explained to the assembled surgeons the procedure to be followed in completing the operation.

This ended the formal demonstration. However, the 3-V Medical Color Camera was kept in operation for the balance of surgery so that the picture could be picked up on receivers placed within the hospital for viewing by hospital personnel.

New Techniques for Teaching Surgery

The demonstration pointed up new methods and techniques for teaching surgery and for the exchange of medical information. While most hospitals have operating rooms with balconies from which student can watch the operating procedure, the new 3-V Medical Color Camera will virtually bring the student right down to the operating table where he can get a surgeon's-eye view of the procedures. A single 3-V Medical Camera, along with associated monitoring equipment, is all that is required. Color itself will lend close-up realism to the demonstration and is destined to be the most important single advance in teaching surgery known today.

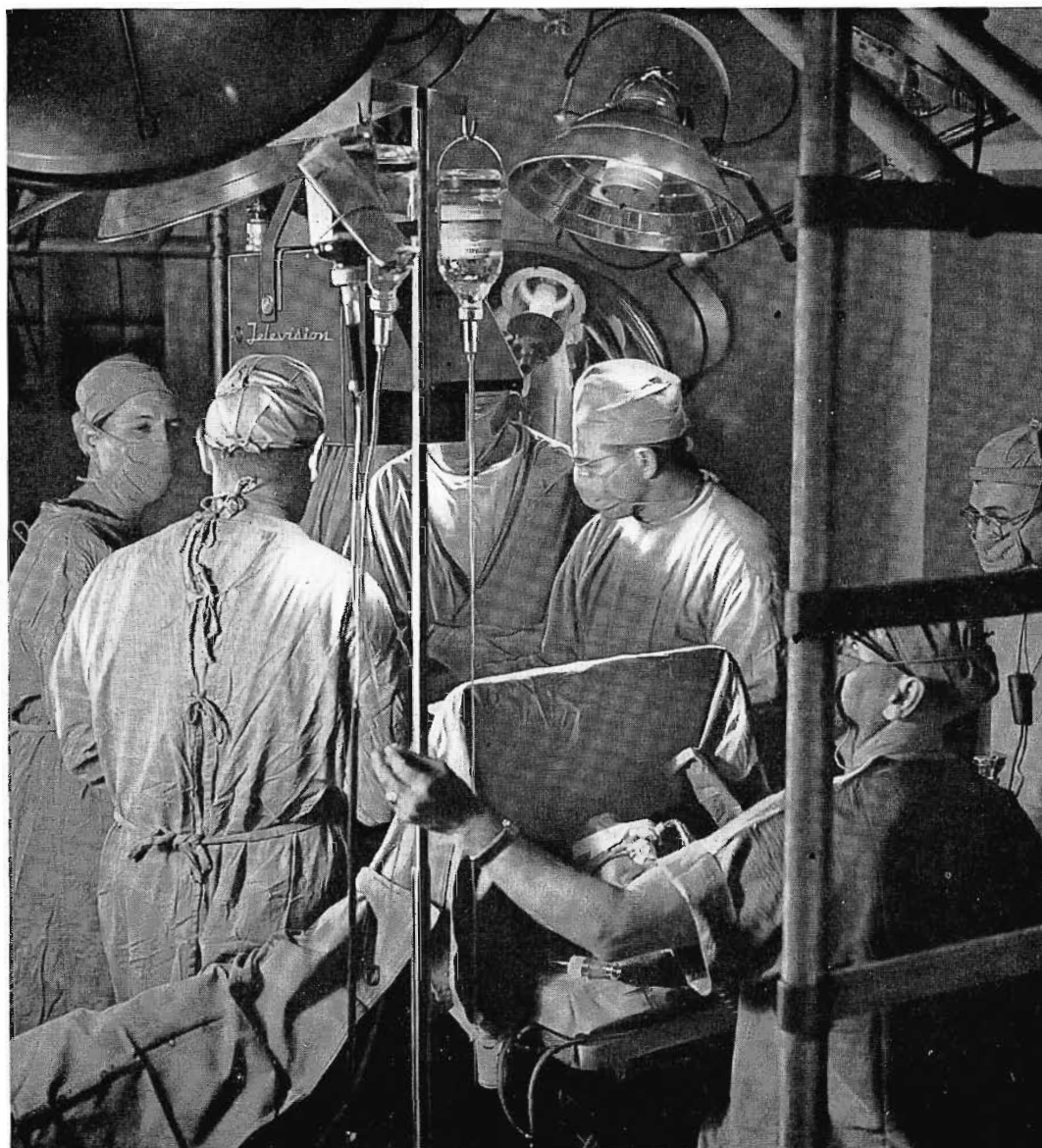

OPERATION. 3-V Medical Camera, suspended from lighting fixture views area of surgery throughout the balance of the operation.

RCA COLOR TELEVISION TO BE USED AT WALTER REED ARMY MEDICAL CENTER

Color TV Will Be Used in Research, Teaching and Consultation

Washington, D. C.—The nation's first installation of compatible color television for hospital use will be made by the Radio Corporation of America to serve three government medical activities located at the Walter Reed Army Medical Center, Washington, D. C.

The installation represents the largest compatible color television system so far developed for non-entertainment applications and will include three separate and complete color television broadcast studios which can be operated independently, or joined for operation as a combined network. Each will be equipped for closed-circuit TV operation as well as for direct transmission to commercial television network lines.

One system will be installed in the new building of the Armed Forces Institute of Pathology, central laboratory for the U. S. Army, Navy, and Air Forces, as well as other government agencies. The AFIP also instructs military personnel in pathological procedures and provides a nationwide consultation service for military and civilian pathologists. The color system will be utilized to further its research, teaching, and consultation services.

A second system will be installed at the Walter Reed Army Hospital, two blocks away, for primary use in the teaching and demonstration of surgical procedures. The installation will also enable the hospital to secure by television the consultation services of the AFIP. This system will provide camera pickups in the hospital surgery and will feature RCA's recently developed three-Vidicon color TV camera for medical use. The camera will be installed in a light fixture overlooking the operating table.

The third system will be at the Army Medical Service Graduate School, which provides military medical personnel with instructions in latest medical, dental, and veterinary techniques. This color system provides camera pickups in research operating rooms and classrooms and permits projection of demonstrations from central locations to selected classrooms.

THIRTY TV MONITORS

Thirty RCA Victor 21-inch color television receivers, distributed among the three locations, will be utilized for viewing the pictures transmitted from the three broadcast studios. The flexible system provides for three methods of signal distribution:

1. The pictures transmitted by each of the three studios can be confined for reception on the receivers connected into a given system.
2. The pictures transmitted by each of the three studios can be fed to a central control at the AFIP building for distribution over an RCA Antenaplex system to all thirty TV receivers.
3. Provisions are made for ultimate relay of signals from any one of the three studios to a projector, in a central auditorium, which can provide large-screen color TV pictures.

The master antenna system provides three channels, one for each of the three separate studios. In exactly the same manner that home receivers are tuned for selection of a given station, each of the thirty monitors can be tuned for selection of telecasts originating from AFIP, the Walter Reed Hospital, or the Army Medical Service Graduate School.

SYSTEM FLEXIBILITY

The independent but interconnected installation provides the government services with maximum flexibility and utilization of the color TV system. For example, it will be possible for a Walter Reed pathologist at the AFIP to view an operation at the Walter Reed Hospital two blocks away. If the removed tissue requires laboratory pathological investigation, it can be sent by pneumatic tube direct from the Walter Reed Hospital surgery to the AFIP. Then, while the surgeon who removed the tissue watches on his TV monitor, the pathologist can prepare the specimen for slide projection and hold a two-way picture and voice consultation with the surgeon.

This initial application of compatible color television, operating over distances

measured in city blocks, makes clearly evident the advantages of televisual consultation. It promises an eventual national medical TV network which will enable doctors, surgeons, and research scientists anywhere in the country to obtain directly the consultation services of specialists, demonstrations of latest advances in surgical and medical procedures, and advanced medical teaching.

The feasibility of such a color television network for medical use had been demonstrated earlier this year by RCA, in conjunction with the AFIP. On January 19, compatible color television was used for the first time as a means of inter-city consultation and diagnosis by pathologists in combating disease. Microscopic views of tissue specimen removed at the University of Pennsylvania Hospital in Philadelphia were sped by television to pathologists in Baltimore and Washington for consultation in the diagnosis. The presentation highlighted a symposium sponsored by the Armed Forces Institute of Pathology to investigate and discuss how color television can best be used in the fight against disease.

SYSTEM EQUIPMENT

The three-studio installation at the Walter Reed Army Medical Center will largely utilize standard RCA color TV broadcast and receiving equipment. Major equipment will include RCA's latest studio color TV camera (TK-41); three 3-Vidicon cameras specifically developed for medical use; a 3-Vidicon color film camera; 30 21-inch RCA Victor home color television receivers; an Antenaplex distribution system; three monitrans, which serve as low-power closed-circuit transmitters; and associated audio, video, intercommunication, and test equipment.

Plans also provide for later installation of a large-screen projector; kinescope recording equipment, for making permanent film records of given procedures and demonstrations; and TV microwave relay equipment, to provide a television link with nearby government military and medical institutions.

KROC-TV

FIG. 1. Air photo of KROC-TV looking east of city of Rochester, Minnesota, taken during construction. RCA TF-12AH Antenna is mounted on 500-foot Truscon tower. The city of Rochester, and the World-Famous Mayo Clinic may be seen in the background.

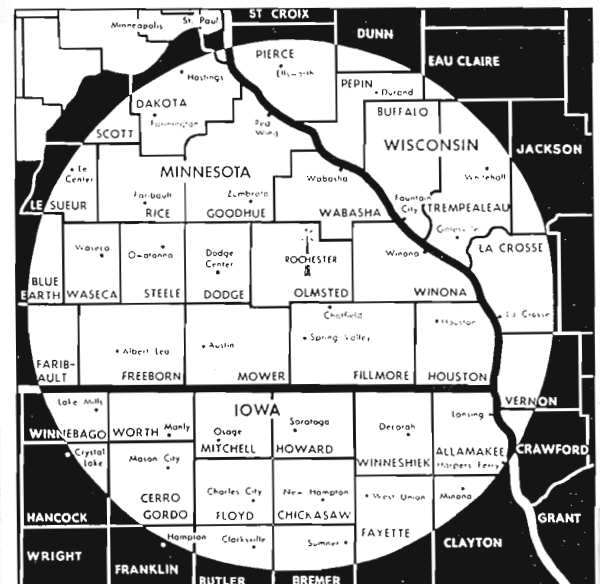

FIG. 2. KROC-TV coverage map.

FIG. 3. KROC-TV building looking northwest as you drive in.

Shows how to achieve efficient low-cost operation

The story of television in Rochester, Minnesota, began back in 1935 when KROC radio began operation. Owned and managed by G. P. Gentling—until his death in 1942—the station grew steadily under his guiding hand. A wealth of experience was gained during these years and was very aptly applied during the planning of KROC-TV.

David Gentling, son of G. P. Gentling, now general manager, and Robert Cross, chief engineer, began laying plans for KROC-TV in 1948. Reams of plans and sketches were drawn, studied, and deposited in the circular file. Layouts of other stations were carefully studied, and more midnight oil was consumed. Finally in the fall of 1952 our present layout was decided upon, after carefully weighing the factors of practicality, efficiency and economic feasibility.

The site on which KROC-TV is built is a 7½ acre plot of land located three miles

by
ROBERT CROSS
Chief Engineer
and
KENNETH STOLTENBERG
Ass't Chief Engineer

west of Rochester. The elevation at this point places the antenna 620 feet above average terrain. Being adjacent to U. S. Highway 14, access in severe weather is assured. An aerial view of the station is shown in Fig. 1 and a contour map of KROC-TV's coverage area is shown in Fig. 2.

The TF-12 antenna on channel 10 is mounted atop a 500-foot Truscon guyed tower. Truscon engineers followed construction progress carefully to make sure every-

thing was correct even though we had a good erection crew.

THE BUILDING

The building design was carried out by station personnel who profited by visits to existing stations. It was decided that a functional, economic design was required which would permit future expansion.

The building is functional because of the central location of the control room which allows two engineers to supervise the entire operation. The design is economical, being of Haydite block construction with Sheffield tile precast roof, with a minimum of interior finishing. Any amount of future expansion is possible because existing room sizes are adequate even for a complete color installation. A second floor may be added, and the building can expand horizontally in any direction.

Original plans called for a studio 36 feet by 50 feet of standard masonry construc-



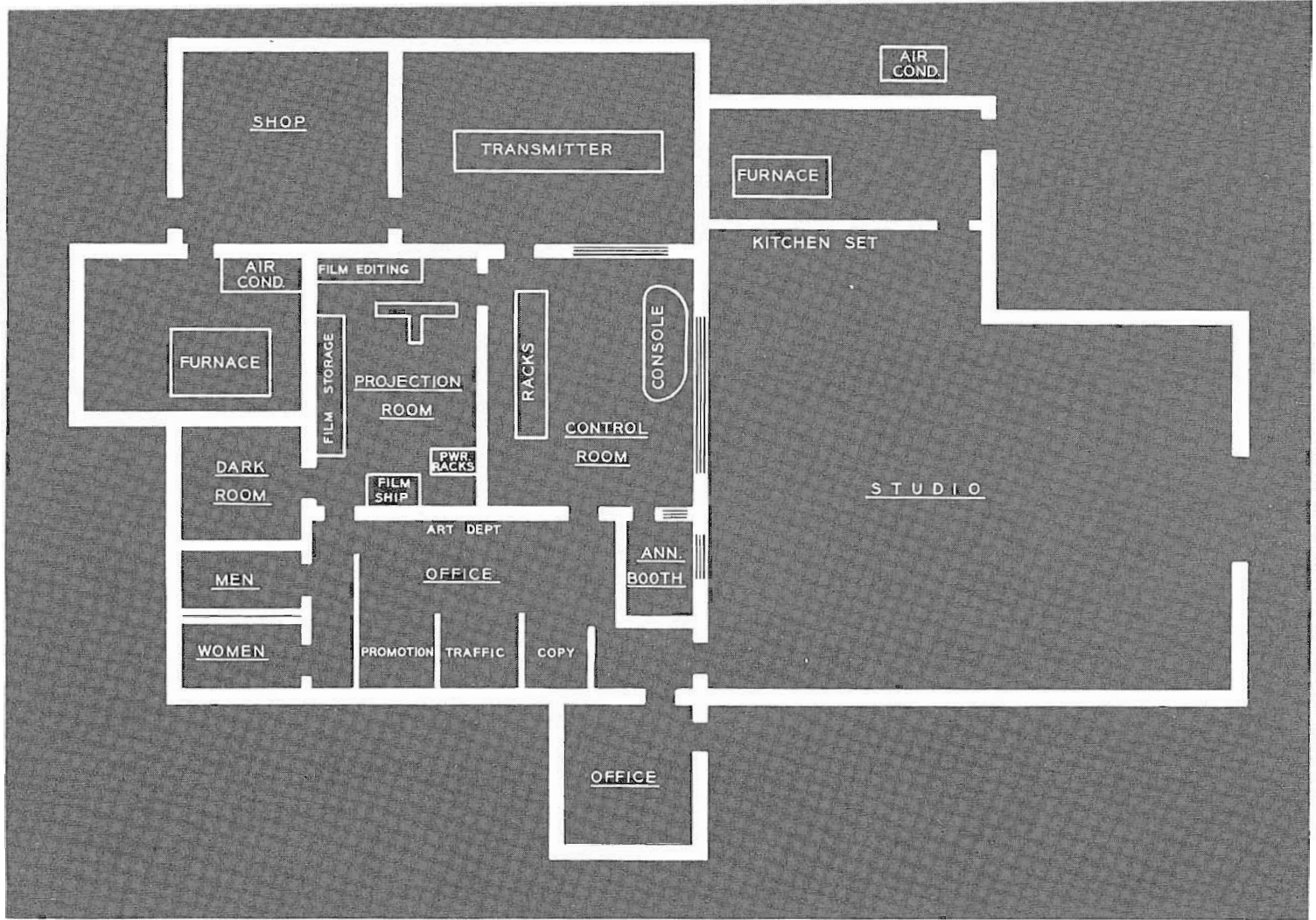

FIG. 4. KROC-TV Floor Plan. Large studio door faces east.

tion. However, it became necessary to cut back on building costs, so the studio was omitted in the original construction, and we utilized our present office space as a studio for the first year of operation. This is a room 14 feet by 24 feet. Everyone, including ourselves, was amazed by the shows we were able to produce in this small floor space with one studio camera. This included news, weather, and sports back to back and even a ten piece orchestra on a weekly basis.

Because of the importance of local production, we decided almost immediately that we would have to expand into a larger studio. Economy was still the watchword, hence we turned to the quonset building shown in Fig. 3. We erected a 48-foot by 32-foot building modified to include an addition along a portion of the back side. This addition also provided a place to construct our kitchen set, and beyond the partition is a furnace room and prop storage room. The insulation consists of a two-inch blanket of fiberglass. Sound isolation is inadequate of course, however, by using lavalier type microphones we are

able to discriminate against extraneous noise. An overall floor plan, Fig. 4, shows how the original building and quonset studio were incorporated.

THE CONTROL ROOM

The control room equipment consists of a basic RCA TC-4A console with a few modifications, a TK-30 film chain, a

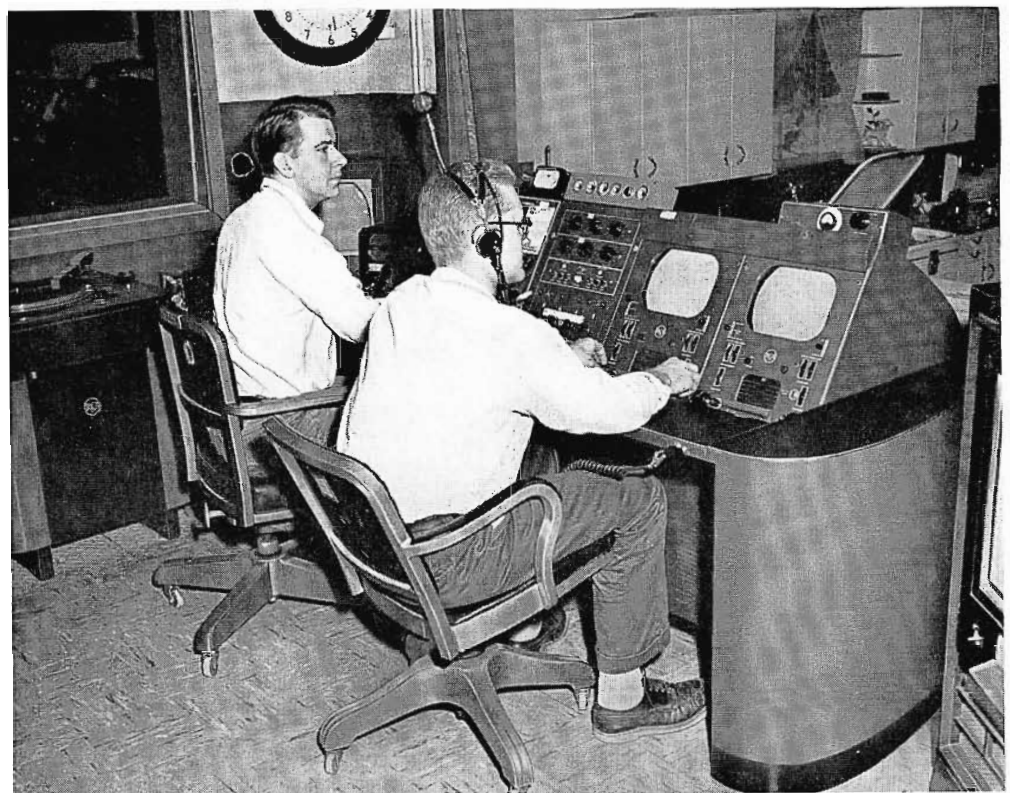

FIG. 5. Control Room. Bill Witte, left; Emil Shustak, right. Part of the kitchen set can be seen through control room window.

TK-11A studio camera chain, and a TT-10AH transmitter. (The station originally went on the air with a TT-2AH awaiting delivery of the TT-10.) The TC-4A was modified slightly as previously mentioned. The Vu meter on the original equipment was replaced with a remote modulation percent indicating meter and a remote meter for the BA-6 limiting amplifier was mounted on top of the housing. The original circuit called for unbalanced 150 ohm inputs for the audio circuits. This was modified to include four input transformers so that 600 ohm balanced lines could be used. This modification was installed to preserve a low noise level in the low level circuitry and facilitate the ease of patching amplifier units when and where necessary.

As can be seen in Fig. 5 the console housing to the right of the TC-4A, begins with a remote control for the RCA RT-11B tape machine. The announce booth also has a remote control panel for the tape recorder. These two additional points of control have proved very worth while. The engineer has control of the tape at his finger tips for use during station breaks or

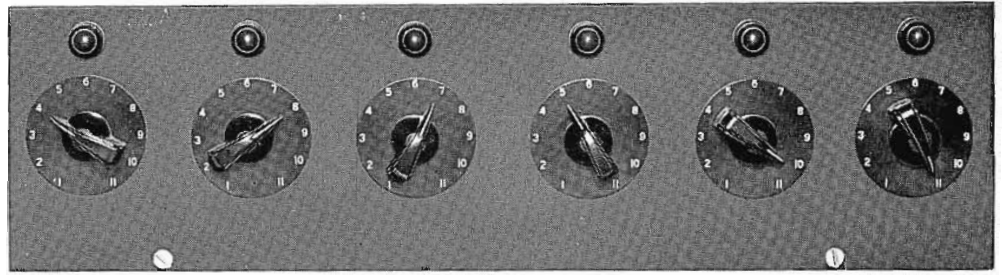

FIG. 6. Mike switch panel for selecting studio mikes.

programs or the announcer can tape spots or breaks without disturbing the engineer at the control board. Below the remote tape control panel are two panels for the two stab amps, the remote panel for the two TP-16D film projectors and the TP-2 slide projector. Below this is an additional audio mixer panel for studio mikes that was designed and built by station personnel. This, in conjunction with another switching panel (Fig. 6) permits any one of eleven studio mike outlets to be switched to any one of six input preamplifiers. Another feature that we believe is unique—as a mike is plugged into an outlet in the studio, a pilot lamp lights above the fader controlling this mike. This innovation was

included to assure that mikes would be plugged in where and when desired. A pilot light is also included in the mike selector panel, above each selector, as a further check when switching.

Five racks are located in the control room just opposite the control console, see Fig. 7. From left to right, rack #1 contains the TK-1B monoscope, video patch panel, two TA-5D stab amps, WA-3A grating generator, MI-27132 low pass video filter, a distribution amplifier and five circuit breakers controlling all control room equipment. Rack #2 is a TG-1A sync generator. Rack #3 contains frequency monitors and frequency deviation meters, two BA-4 audio

FIG. 7. Equipment racks in KROC-TV control room.

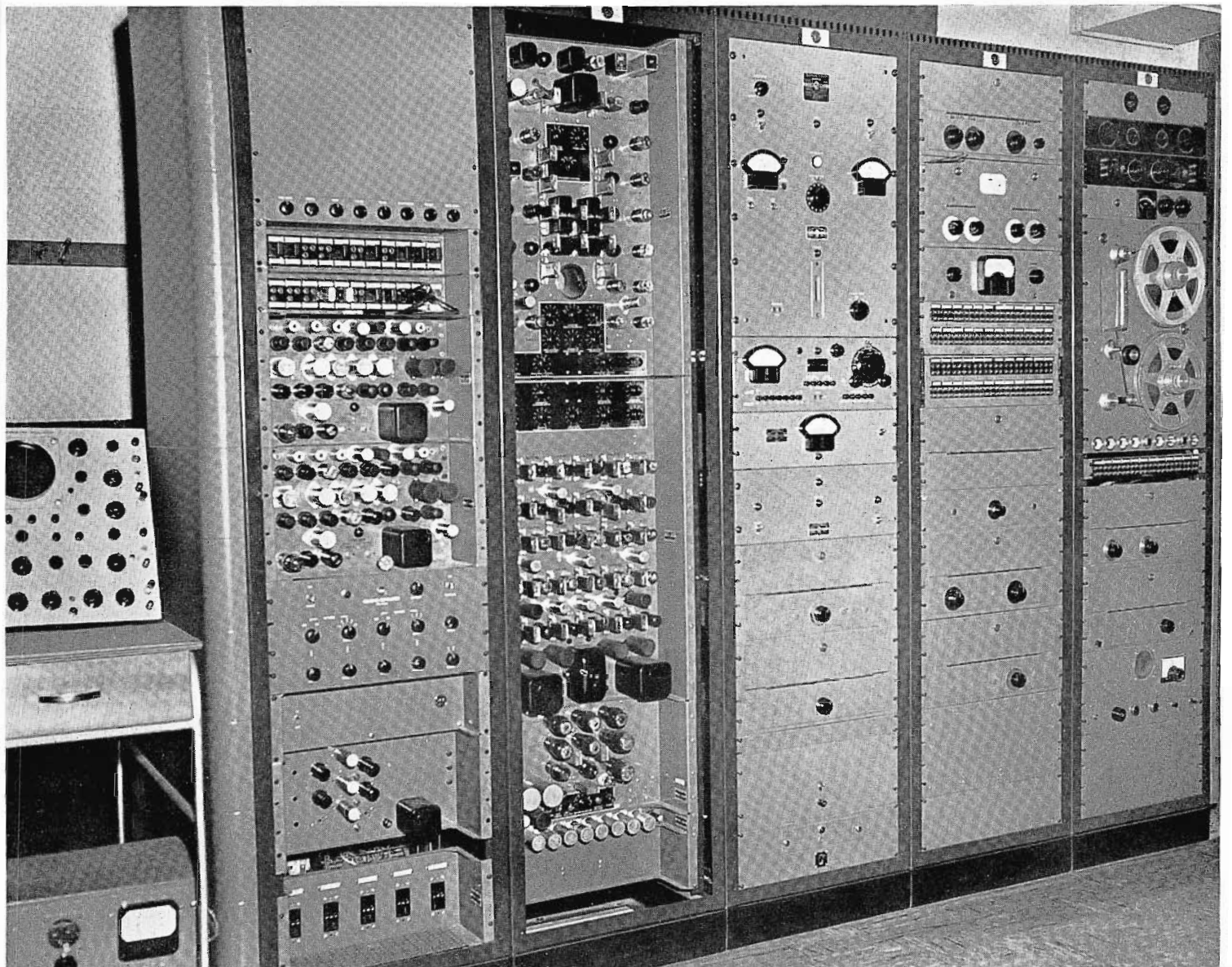

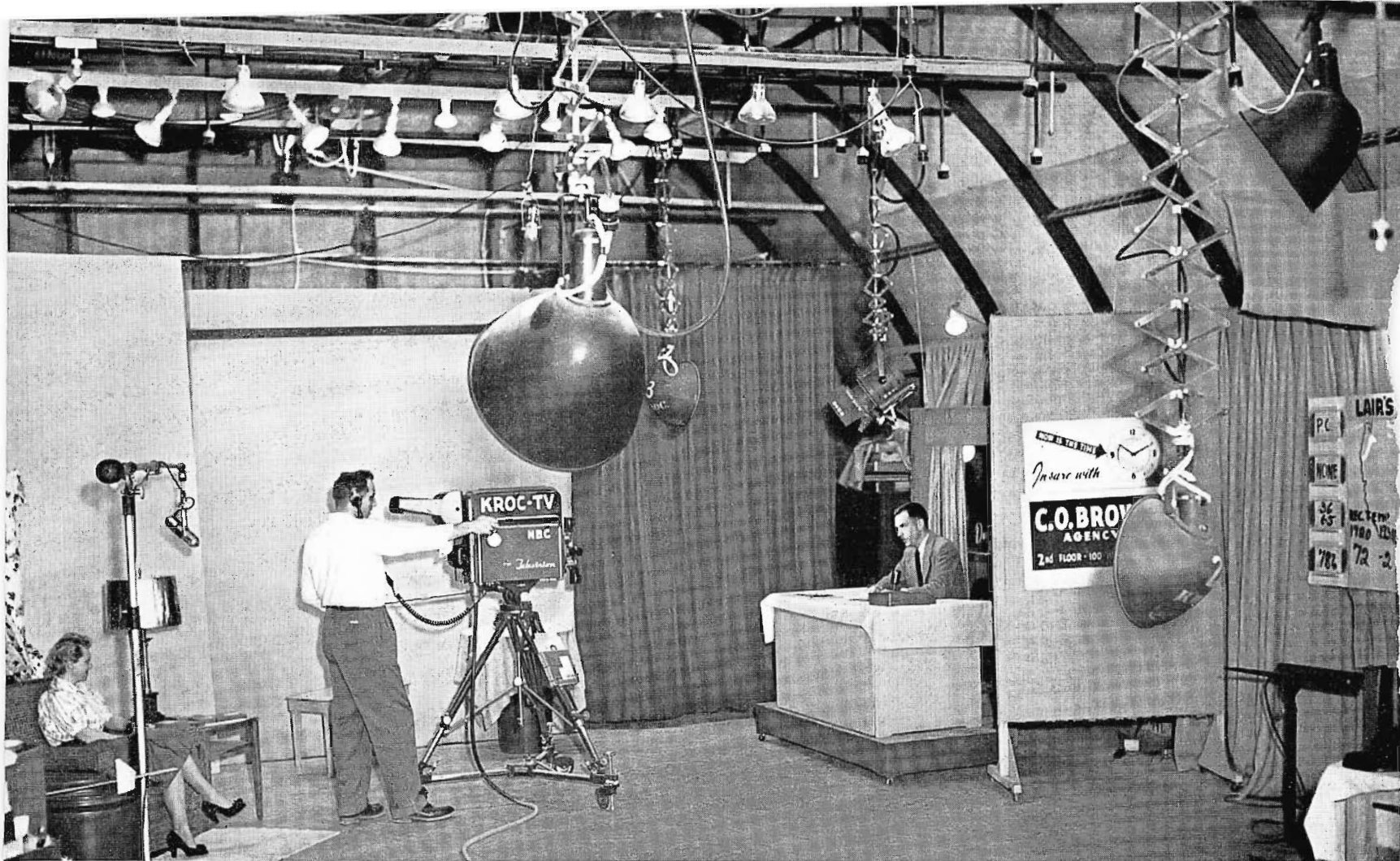

FIG. 8. Studio—east end. Bob Heiden, camera man—Ray Thompson, news director at news set—Phoebe Thompson on commercial set. This combination used on news cast sponsored by Dayton's—the largest department store in the area.

amplifiers—one of these is used for a monitoring amplifier and the other is used as a cueing amplifier. Below these is a 24 volt d-c power supply. Rack #4 is the main audio rack. From top to bottom, two BA-13's, a BA-6 limiting amplifier, a Vu meter with selector switch to check levels at desired points in the system, a patch panel, six BA-11's, two BA-2's, a BX-1E power supply and a BA-2 and below this is a relay panel for speaker interlocks and signaling circuits. The 5th rack begins with line filters, a variable filter, a variable pad, the RT-11B tape recorder, an additional audio patch panel, the associated amplifiers for the tape recorder—below this two BA-2's and a conelrad receiver. Not shown in the picture (Fig. 7) of the control room equipment is a rack of color equipment which was added in time to present the World Series in Color. The equipment includes a TA7-B stabilizing amplifier and the required phase equalizers.

An RCA CT-100 color receiver was "jeeped" and has made a satisfactory control room monitor.

In November, 1953, the microwave interconnection was completed and the AT&T receiving equipment was installed in the engineering shop and office.

THE STUDIO

We have continued operating with only one studio camera but we don't feel that this has left us short handed, except of course if we should experience a major breakdown. The camera is equipped with the standard variety of lenses, 50, 90 and 135mm, and has a remote iris control for each. The cameraman provides skill, agility, and pride in the product he releases. A typical studio scene (Fig. 8) shows the single camera in action.

The slide projector, or film chain, is used as a bridge to move the camera from one scene to another. For example, during a news cast the newscaster writes his script so that a slide, usually some prominent figure in the news, precedes and follows the commercial, of which we have ever increasing numbers, allowing the cameraman to move from the newscaster to the commercial display and then back again. As we have always been used to this type of operation, it has become a habit and seems rather simple to us. We have had many visitors, both in the business and otherwise, who, having seen our operation on a television set, expect to see a two-camera operation when they visit us in person. This we believe speaks well of the ability of our staff.

The lighting grid consists of 1½-inch pipes supported from steel rods that are bolted to the main frames of the quonset studio building. These pipes are 4 feet apart and run the length of the studio. A 4-inch square duct lays on top of these pipes in the center for the length of the studio and acts as a power distribution point. The square duct is fed from a 36 breaker distribution panel.

A large door was incorporated in the end of the studio. The studio floor level is about three feet above the outside ground level at this point so that trucks can back up to the studio for easy loading and unloading of display merchandise. A portable ramp was constructed so that cars can be driven into the studio for display. The ramp was another "home designed and built" item. Among our shop equipment is an acetylene gas welding rig that has paid for itself many times over. Aside from the ramp construction, it has come in handy on numerous occasions to assist in the construction of some item needed at the moment.

PROJECTION ROOM

The projection room includes the two TP-16D 16mm projectors, a TP-12 slide projector, and all power supplies for con-

trol room equipment. All film is edited, stored and shipped here. "Visiting firemen" usually comment on our method of mounting the film chain (see Fig. 9). An angle iron base frame was constructed from RCA specifications. The projectors, film camera, and multiplexer were bolted to this frame after the frame was placed over the wiring trench. This made for ease of mounting and if future occasion demands, the unit as a whole can be moved within the projection room with relative ease.

A small station depends heavily upon its film chain, as much of the program material is on film. We understand that we are one of the very few stations in the country to do our own projector maintenance. It is our premise that the more our personnel knows about its equipment, the quicker it can be returned to normal, should some difficulty arise. Although the TP-16D film projectors have given very satisfactory service, they are completely overhauled at 100 hour intervals, or as close to it as is practical. Parts that show any signs of wear are ordered and are on hand when replacement becomes necessary. After living with these projectors for over two years and a total of 3200 hours of film operation, we feel we are able to spot trouble well in advance of its causing a breakdown.

HEATING AND AIR CONDITIONING

The main building and studio have separate air-conditioning systems. This was due to the fact that they were built at different times and it was more practical to do it this way even though the location and approximate studio size was known when original construction got under way. Both have oil burning furnaces and separate air-conditioning units. These systems make use of the furnace blowers for both summer and winter operation. During the winter months the air flow is prevented from passing through the condensing coils by means of dampers. An 8-ton water cooled unit is used for air conditioning the main building. The water used in this unit is cooled and reused through the use of a cooling tower on top of the building. A 5-ton air cooled unit located in a weather proof enclosure just outside of the prop storage shed is used to air condition the studio. The main air distribution ducts are lined with a one-inch fiberglass blanket to prevent sound distribution through the air conditioning system. A well-designed air conditioning system can provide an atmosphere that is a pleasure to work in.

What might be classified as the air-conditioning system for the transmitter room, falls in a class by itself as it grew with the

building. As originally laid out, fresh air from the outside is drawn in through a louvered housing containing twelve 18-inch by 24-inch spun glass filters. This design is well below the recommended maximum of 500 LFPM (linear feet per minute) and thus lessens the vacuum created in the room when the exhaust fan is in operation. The exhaust fan incorporates a two speed motor and is thermostatically controlled. During the winter months, the hot air is removed from near the ceiling and is recirculated through the rest of the building to help heat it and reduce the fuel bill. Since the new studio was added, another tap was placed on the hot air supply. A duct was run from the studio air conditioning system to the transmitter room. Dampers in this duct, operated by an independent thermostatically controlled system, can open if it is sufficiently warm in the transmitter room (above 80 degrees) and if the studio calls for heat, thus aiding in the reduction of the studio fuel bill. A safety feature was incorporated with the introduction of another thermostat that operates an alarm bell in the control room in case the temperature rises above a predetermined point.

TRANSMITTER ROOM

The engineer on duty at the control board can, by looking to his left, see the transmitter through a 3½-foot by 7½-foot double paned window. This allows complete

visual supervision of the transmitter operation. The wall between the transmitter room and the control room is constructed of 12-inch Haydite blocks as are other walls of the building, possessing a relatively high sound absorbing quality, little noise from the transmitter is transmitted to the control room.

Fig. 10 shows a portion of our 10 KW transmitter. In the picture of Fig. 11, the location of the plate transformers, filament regulator controls, and the outgoing coax lines can be seen. The side band filter and WM-20 are suspended from two 4-inch by 4-inch angle irons that are bolted to the ceiling. The bolts supporting these angle irons were incorporated during the roof construction. The heads of the bolts pass through 6-inch square pieces of half inch sheet steel to spread the load. These two units being directly over the transmitter makes for a compact installation. The diplexer is located on a plane just below the side band filter behind the transmitter. For convenience the dummy load was mounted on the wall near the diplexer and can be connected and interlocked to either the aural or visual feed to the diplexer. As the dummy load is water cooled, proper plumbing was included during construction.

The flasher for the tower lights is located in the transmitter room and here again we have included a few of our own innovations and we think improvements.

FIG. 9. Detail of film chain mounting angle iron base frame.

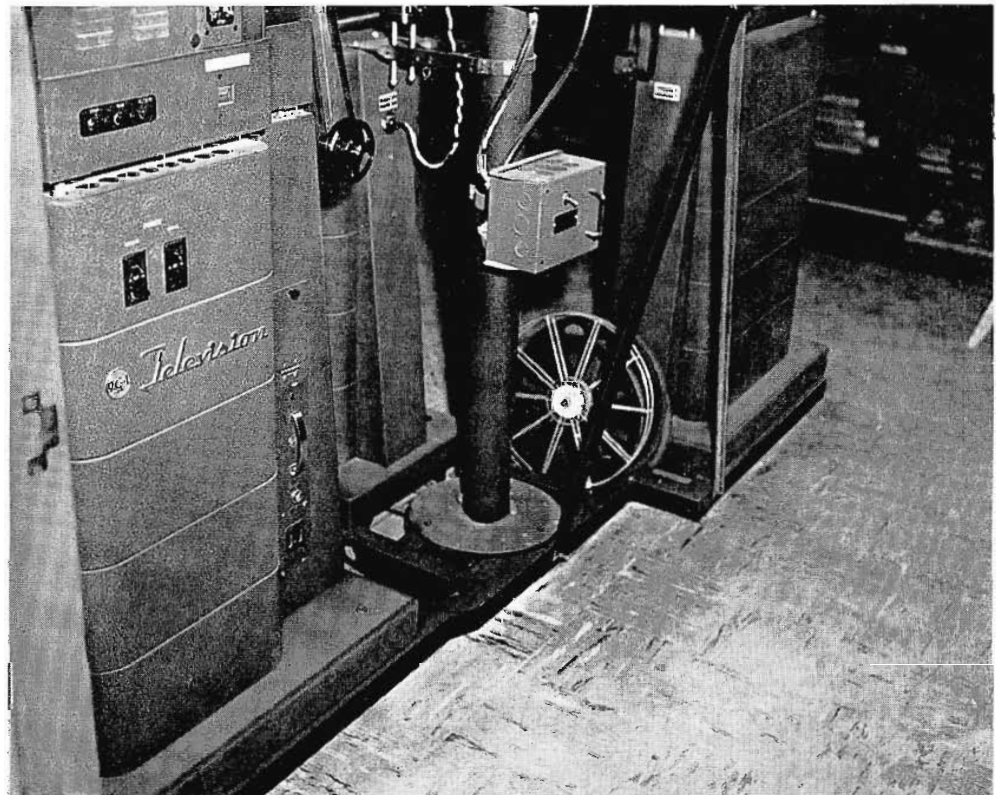
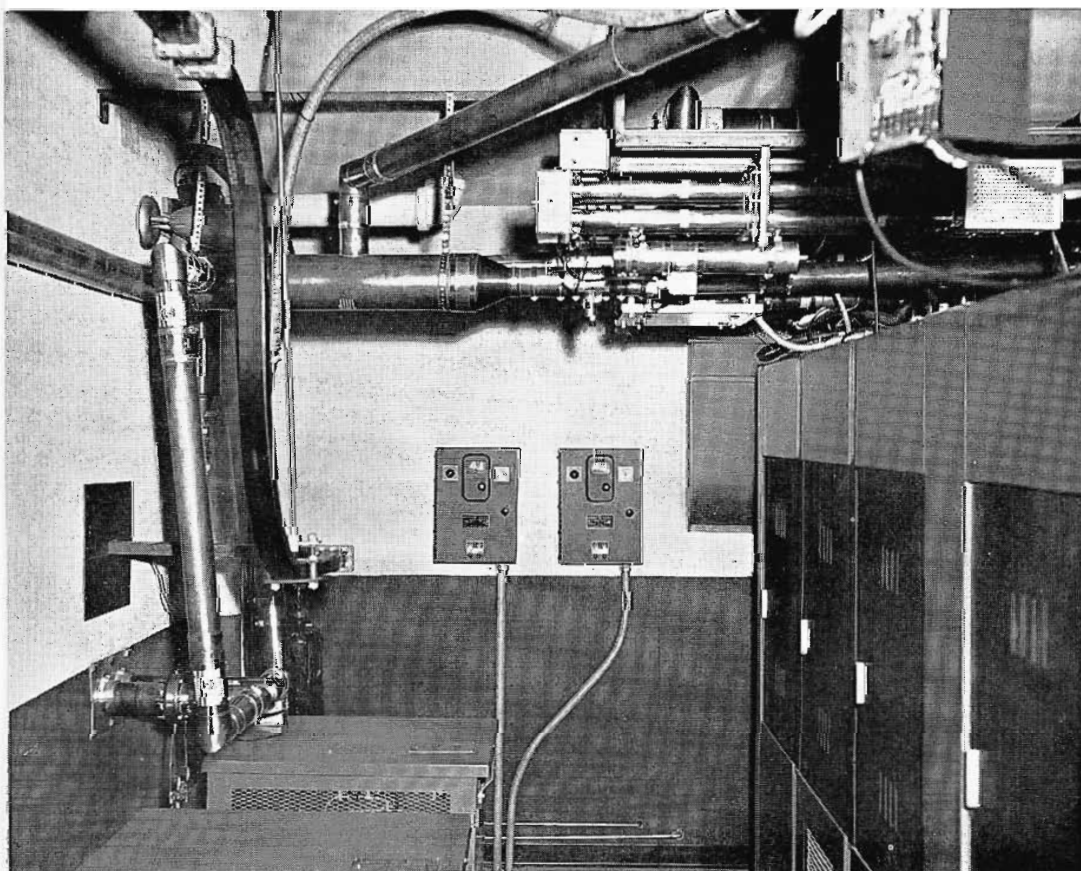



FIG. 10. Engineer (Reuben Rieck) shown taking meter readings.

FIG. 11. Rear view of transmitter showing plate transformers, diplexer, coax lines leaving building, filament regulator controls, WM-20 and part of side band filter behind it. Parts of dummy load is visible behind vertical output coax diplexer. Wave guide is AT&T equipment between the antenna and the microwave receiver.



The tower lights are turned on and off by a photo-electrically operated unit as is customary. The flasher was modified to include resistance units mounted on the wall in a well-ventilated steel grill. These are connected across the flasher contacts. The resulting operation permits the filaments in the beacons to decrease to a dull glow when the flasher contacts are open. This reduces the surge of current that would normally occur when closing the circuit to a cold filament and thus increases the life of the beacon lamps.

To permit constant observation of the tower lighting operation, the following were added: two low resistance rheostats in series with the tower lights—one in series with the beacons and the other in series with the obstruction lights. These cause a drop of only several volts which for all practical purposes is immaterial. The voltage developed across these rheostats is fed to two calibrated a-c voltmeters located above the window in front of the control panel in the control room so that the engineer on duty can at all times determine instantly the number of lights in operation.

OPERATION

We feel that the key to our successful low cost operation is due in a large part to the abilities and the pride that members of our staff take in turning out a high quality product. Most of the staff members are versatile enough to be able to fill in on several other jobs and produce, very acceptably, should the occasion demand. Having a working knowledge of the other man's job creates an incentive for cooperation. This may also be expressed in terms of team work, as we are ever striving to release the type of programming that we can be proud of and at the same time this keeps the sponsor happy.

Programming hours have been expanded considerably over the last year. On week days, the 7:00 A.M. sign-on brings NBC's "Today" to the area viewers and the full morning lineup is presented. At noon, we sign off for three hours, then at 3:00 P.M., operation is resumed and continues until midnight. The mid-day off-the-air period is used to take care of routine maintenance duties.

If you were to look in on our normal operating routine you would observe one engineer operating the control console (except during a live studio show). He rides audio levels, controls levels and shading on the film camera, controls slide and film projectors, inserts tapes or discs when called for, and does audio and video switching. This may sound overly complicated but one might compare it to operating a typewriter. When you have learned how

to operate one, you don't stop to think what letter comes next or where on the keyboard it is located because these operations have become automatic. The second engineer on duty operates the camera control during live shows, gives cues to the cameraman and keeps the transmitter log. During times when there is no live show in the studio, aside from keeping the transmitter log, he is available to lend his assistance in the projection room or elsewhere where he might be needed.

The projection room is normally manned by one man who does all the film editing, timing, and keeps the film and slide projectors loaded. One man handles the film shipping and receiving, the art work, makes slides, and does a large share of the dark room work. We have a news photographer who works in the area and also works in the dark room.

Our news photographer takes on the average of 100 feet of negative 16mm movie film a day. This is processed by hand in our dark room in less than an hour's time. The film is then used to snap up and enhance the appearance of both news and sports shows and provides an increased coverage of events in our area.

In production, we have several announcers, one girl handling traffic, one girl handling copy, a promotion director, a sales manager and several assistants. The studio is handled by two men who can run the camera, build displays, props, and supervise the studio. The over-all operation is directed by the manager, the chief engineer and the program director. Thus only eighteen people are employed full time in television. A sports director and two news men share time between radio and television. This is a minimum staff but we wonder at times if it is not better than having too many people getting in each others way.

THE FUTURE

The future looks increasingly promising. The original building was designed, as much as our crystal ball would permit, to take care of anticipated expansion. The control room has space left to include six additional racks of equipment and many more can be installed in the room now being used for office space. Floor trenches and wiring facilities are there when required. The present control console can be extended to more than double its present length. Also there are seven acres of

land over which the building could be stretched if need be.

As color is becoming increasingly popular, we have added equipment to rebroadcast network color and at some future date, plan to add color film and slide equipment. The color programs have caused a great deal of enthusiastic comment in the area from people who are seeing RCA compatible color for the first time. Dealers have reported numerous set sales as proof of viewers interest. Of course original costs and operating costs can change this picture, too. Already in our expansion plans is the increased service we can render by an increase in power. The exact timetable has not been set up as yet; however, the first step will be the modification of our TT-10AH transmitter to a TT-50 which will allow operation at 316 KW effective radiated power. The second step will be an increase in antenna height by the addition of a 1000-foot tower.

To touch a bit on the romantic—we stand on the bow of our TV ship looking forward to the wide and intriguing horizons that lie ahead. We believe that other stations in similar market areas can solve the problems of low cost operations as we have done.

FIG. 12. Looking southwest—Quonset studio with modification. Small sheds are used for additional prop storage. Parts of portable ramp can be seen lying in front of studio door. Dish antenna 50 feet up on tower is AT&T microwave equipment to bring NBC network shows.



CONTROL OF LIGHT INTENSITY

by K. SADASHIGE and B. F. MELCHIONNI

RCA Television Engineering

The use of the vidicon in television film cameras has introduced a new requirement, which is, the need for maintaining a constant signal level in the system regardless of wide variations in film density. The iconoscope, because of its inherent action as a limiter, handled such variations fairly satisfactorily. This article shows how the vidicon, combined with a variable neutral density filter (for controlling light intensity), forms a film system that produces pictures of superior quality.

The vidicon, though it has a "gamma" of less than unity in its present form, re-

sponds to light variations over a wide range. This is a desirable characteristic in one sense because it permits much more accurate reproduction of tonal gradation in picture whites, but on the other hand, some method is required for restricting the range of light to values suitable for the system.

Presently available film is so variable in average density that a method of controlling the intensity of the light source is desirable. Broadcasters often have to deal with variations of up to 100 to 1 in film from different sources. Adjusting video am-

plifier gain over such ranges is limited because of resulting variations in signal-to-noise ratio.

Generally, video amplifier gain controls have been acceptable when used with the single-vidicon type of equipment, however, this system is not suitable in the three-vidicon color system where the gain of three amplifiers must track as they are varied.

Light-Intensity Control Methods

Several methods of controlling the intensity of the projection-light source have been developed for the purpose of main-

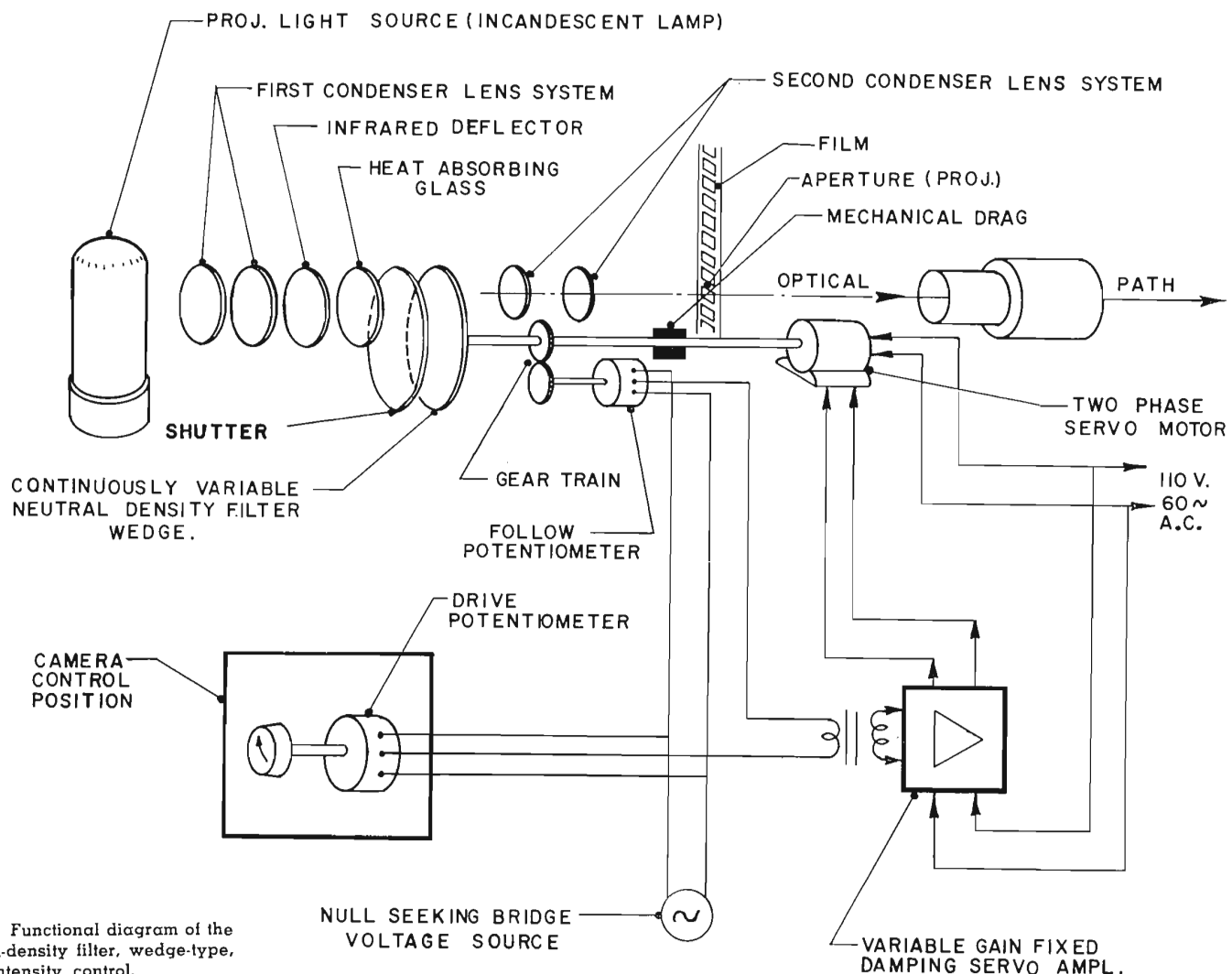

FIG. 1. Functional diagram of the neutral-density filter, wedge-type, light intensity control.

IN TELEVISION PROJECTORS*

taining a constant video level output from the film camera, and these will now be considered.

Although it is not a true form of light-intensity control, irises have been used extensively for television cameras. The most serious disadvantage of this method is that the depth of focus of the field is a function of the opening.

If the iris is used in a television film projector, the flatness of the projected field cannot be maintained over a wide range of iris opening. Unwanted surfaces, namely, condensing lens optics and lamp filaments, will come into focus when the iris is stopped down.

Controlling the source voltage of the projection lamp has also been employed. The source voltage may be controlled locally by a variable auto transformer or remotely by a controlled saturable reactor. However, this approach to the light-intensity control problem is not practical if it is applied to color-film reproduction, because the spectral energy distribution of an incandescent lamp is a function of the temperature.

By taking, for example, 550 millimicrons (green) as an arbitrary reference the relative intensity of the 700-millimicrons (red) wavelength is increased by 40 per cent while the 400-millimicrons (blue) wavelength is reduced to only 70 per cent of the standard value when the source voltage of a 120 v, 1000 w projection lamp is reduced to approximately 60 v. Under this condition, the over-all visible light output level of the lamp is 10 per cent of the nominal value. This method of light control is acceptable in monochrome systems using the vidicon tube.

A more satisfactory approach is to control the transmission of the optical system. For this purpose, there has been developed a device to control the illumination of a projector aperture by varying the angular position of a continuously variable neutral density filter wedge. This device compensates for the varying density of the film

and maintains a constant video output level.

This type of light-intensity control has the following distinct advantages over the other method:

- (1) The spectral energy distribution of the projector light output is essentially constant because the filter wedge used in the device is neutral in the visible spectrum.
- (2) A wide range of control is available. A light intensity range of 100 to 1, which is more than adequate to handle most color and monochrome films, is obtained by using a filter wedge approximately 6 inches in diameter.

A limitation of the system using a neutral-density filter wedge is that the filter is made of carbon particles suspended in a gelatinous medium, and being an organic compound, the gelatin is subject to deterioration by heat. This problem is further complicated by the fact that, in order to remove the effects of shading caused by the density gradient of the filter wedge, it was placed in the condenser-lens system of the projector. How this problem was solved will appear as we consider the de-

velopment of the neutral-density filter system.

How the Neutral-Density Filter Works

Fig. 1 is the functional diagram of the neutral-density filter, wedge-type, light-intensity control. The filter wedge is placed in the condenser lens system of a typical film projector. The filter wedge, as shown in Fig. 2, is made of a wratten filter sandwiched between two pieces of optical-glass plate to give sufficient rigidity for mounting. The density of the filter varies continuously from 0, or essentially 100 per cent transmission, to 2, or 1 per cent transmission with a gradient of 0.006 density unit per degree of angular rotation.

The center of the filter portion of the wedge is placed in the axis of the optical path. Horizontal shading due to the density gradient of the filter wedge is noticeable when it is placed other than in the condenser lens system. By integrating the filter wedge into the condenser-lens system the observable shading has been eliminated.

* A Paper Presented at the Semiannual Convention of the Society of Motion Picture and Television Engineers, April 18 to 22, 1955, Drake Hotel, Chicago, Ill., and printed in the August 1955 Journal of the SMPTE.

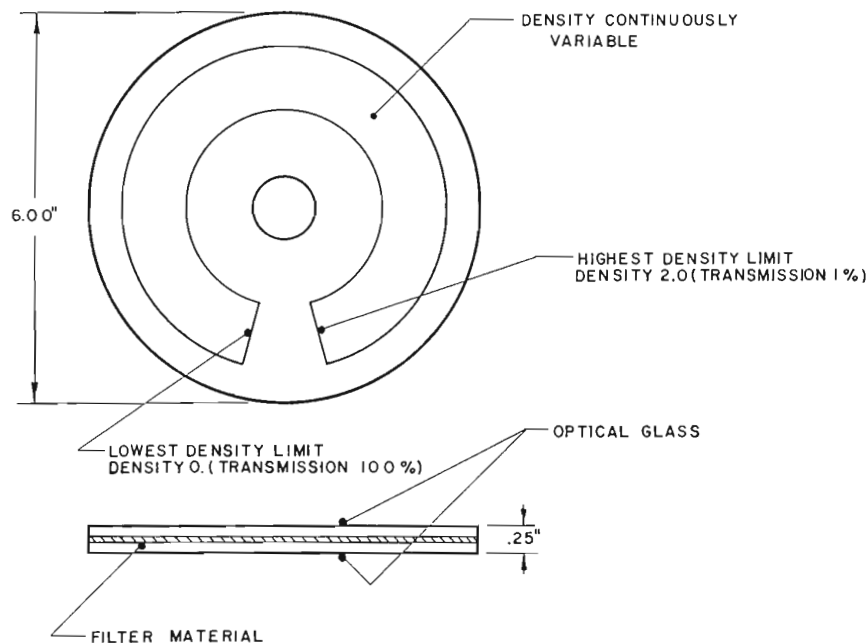

FIG. 2. Outline drawing of the filter wedge used in the light intensity control.

In the condenser-lens system, infrared rays, as well as visible light, are highly concentrated. The intensity of the infrared rays is sufficient to raise the temperature of a black body to 250 C within a few seconds after it is placed on the axis of the condenser lens system of an RCA Type TP-6 16-mm film projector. At this temperature, the gelatin material of the filter wedge will be damaged within a matter of seconds. By placing two infrared filters between the light source and the filter wedge, the temperature of the filter wedge is held below 60 C. This has proved to be a safe temperature for the filter material.

Bridge Circuit

A potentiometer is coupled to the drive shaft of the filter wedge by a gear train. Another potentiometer is located at the camera control position. These two potentiometers form a bridge circuit as shown in the schematic diagram of Fig. 3.

The difference in electrical potential between the arms of the two potentiometers

is fed to an a-c servo amplifier. The output of the servo amplifier is fed to one of the two fields of a 2-phase servo motor and, in turn, the servo motor drives the neutral-density filter wedge. The servo amplifier and two potentiometers form a null-seeking bridge circuit.

If a potential difference between the output of two potentiometers exists, the output of the servo amplifier drives the following potentiometer, which is coupled to the servo motor by a gear train, until the potential difference between drive and following potentiometers becomes zero. The following sequence thus takes place: The output signal of the servo amplifier becomes zero; the servo motor develops no torque; and the filter wedge stops at a specific point.

The camera operator can, therefore, remotely control the angular position of the filter wedge by merely rotating the driving potentiometer at the camera-control position. There are no mechanical connections or linkages between the filter-wheel mech-

anism and the driving potentiometer. The camera-control position can be located anywhere in the studio and interconnections can be made by a conventional two-conductor, shielded microphone cable.

As is often the case in servomechanisms, a degree of mechanical oscillations of the filter wedge was encountered. The electrical damping introduced into the servo amplifier was insufficient to eliminate the oscillation because the moment of inertia of the filter wheel was fairly large. Oscillation of the disc was eliminated from the system by introducing a mechanical drag to the filter-wedge drive shaft.

Solving Development Problems

First we had to determine the most suitable type of remote control system to use. Initially, a combination of synchro transmitter and receiver was proposed. Using this system, however, the mechanical drag of the filter drive mechanism is reflected back to the control knob whereas, in the

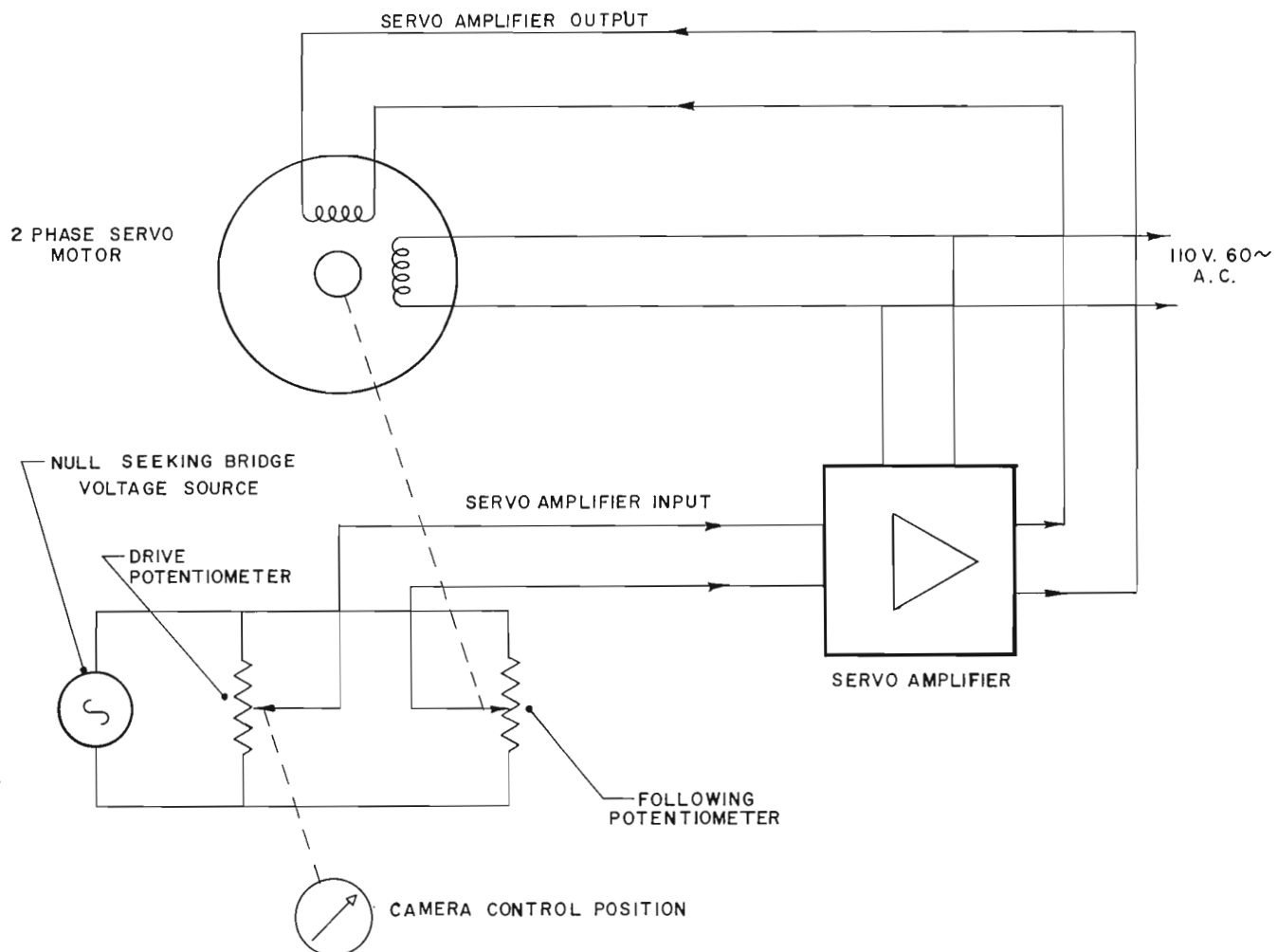

FIG. 3. Bridge circuit which drives the filter wedge.

system finally selected this condition does not exist.

A simple form of position servomechanism was finally chosen on the basis that it offers the following important advantages:

- (1) Reaction time could be shortened to a point where there was virtually no time lag between the rotation of the control knob and motion of the filter wedge.
- (2) By combining mechanical and electrical damping an extremely smooth operation could be assured.
- (3) The operator retained the "feel" of the control without the disturbing effect of mechanical drag.

The second but more serious problem was that of removing the infrared rays from the optical path, before reaching the filter wedge, without distorting the original spectral-energy distribution in the visible range of the projection lamp.

Eliminating Infrared Rays

If the filter wedge is stationary for a period of time, even a small amount of infrared ray may cause damage to filter material. Infrared accumulates in a small spot on the filter raising its temperature to a dangerously high point.

To block off these rays, a filter having a sharp cutoff at about 700 millimicrons was required. A sharp dip at 1000 millimicrons is especially effective because this wavelength is the primary source of infrared from an incandescent lamp. Proper selection of the infrared filters is of utmost importance because it may alter the color characteristics of the projection lamp around which the television color film reproduction system has been designed.

Two infrared filters were finally selected. One a Fish-Schurman Type XUR infrared deflector, and the other a Pittsburgh Glass Works Type 2043X heat-absorbing glass (tempered). These are placed in the optical path between the light source and the neutral density filter wedge. Characteristics of the filters used in the system are shown in Figs. 4 and 5 respectively.

As shown in Fig. 6, the combination of two filters transmits less than 1 per cent at the wavelength of 1000 millimicrons which is the prime source of the heat from an incandescent lamp. Transmission characteristics at 700 and 600 millimicrons are 50 and 74 per cent respectively.

Adapting the Control to Projectors

The system described thus far placed the neutral-density filter wedge in the projector at the optimum position for least shading error, namely in the crossover re-

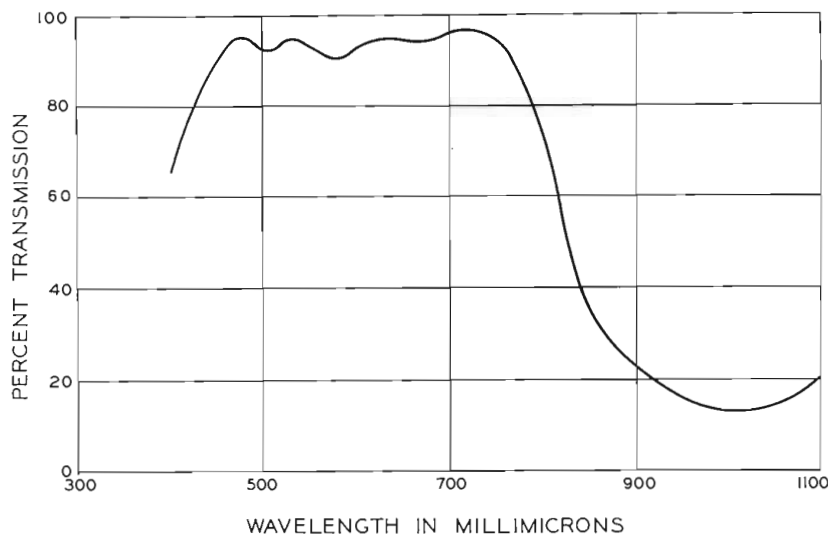

FIG. 4. Spectral transmission curve of Fish-Schurman Type XUR infrared deflector.

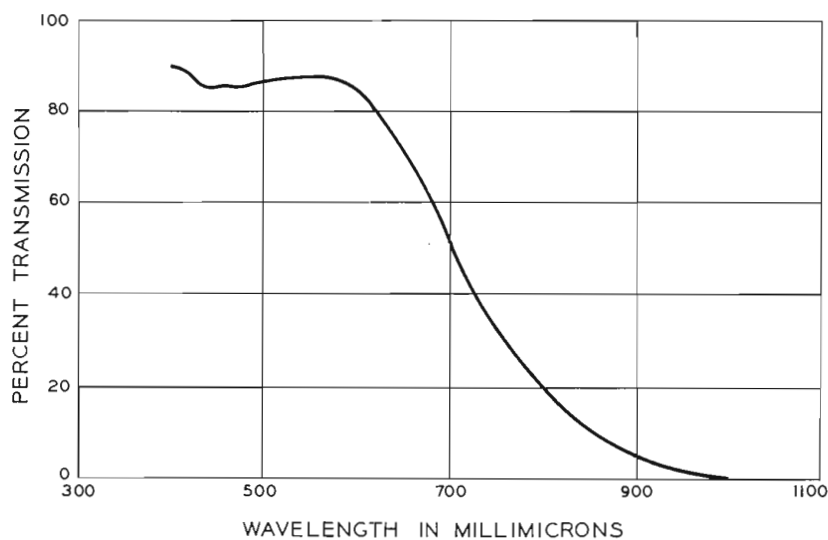

FIG. 5. Transmission characteristics of Pittsburgh heat-absorbing glass Type 2043X 4mm thick.



FIG. 6. Transmission characteristics of infrared filter combination.

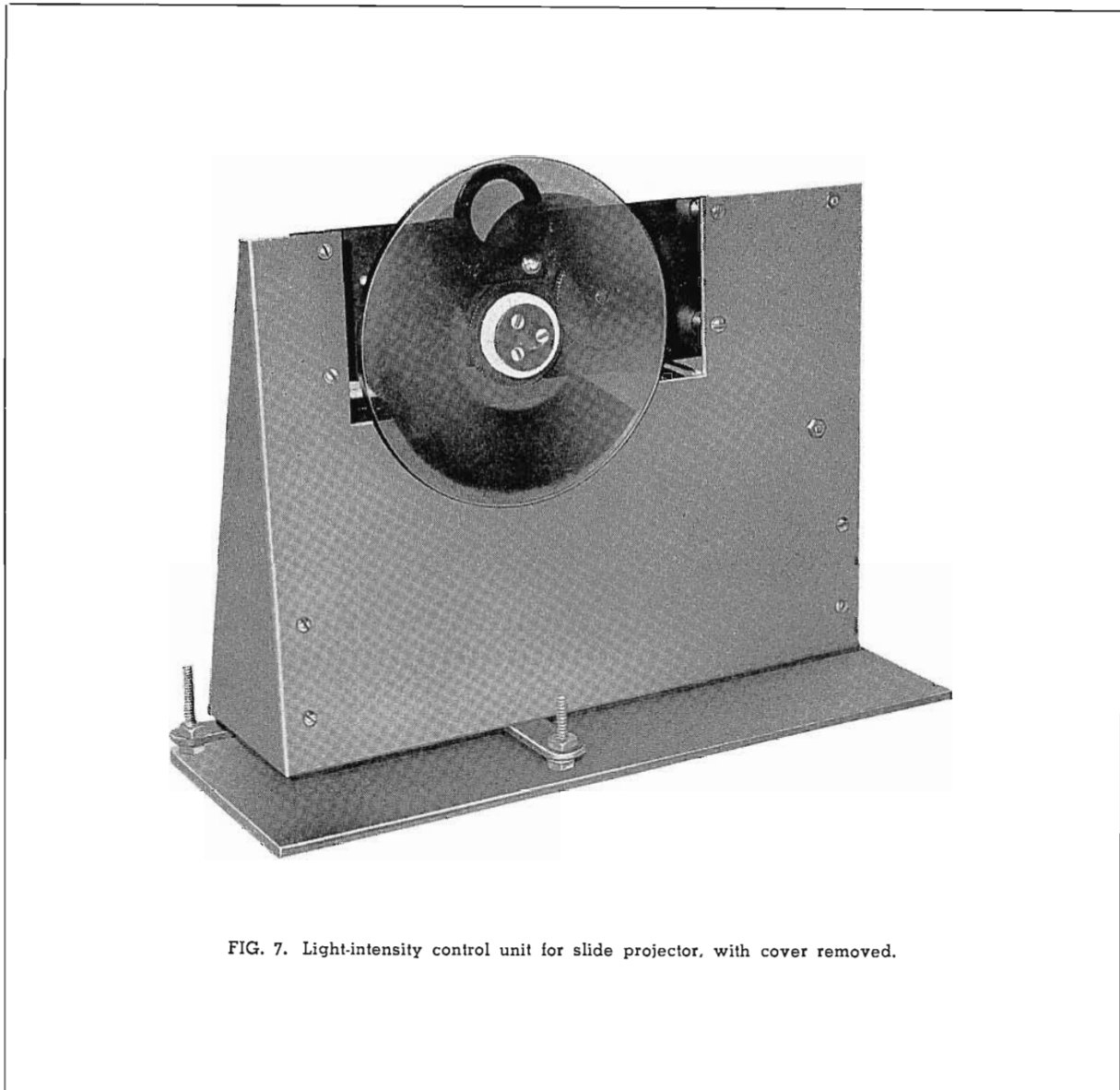

FIG. 7. Light-intensity control unit for slide projector, with cover removed.

gion of a relay condenser system. However, it is obvious that this is not always possible when attempting to utilize existing equipment.

A neutral-density light-control unit has been designed which may be used with any projector where this type of control is required. Although designed primarily for use with slide projectors in the 3-V camera system, it can be used in the optical path of any projector providing there are no physical limitations.

This unit, shown in Fig. 7, is a complete self-contained package. It includes the servo amplifier, drive motor, gear train, and neutral-density wedge. This unit need only be supplied with 110-v 60-cycle power and three conductors from a remote control location.

It was obvious that, because of the density gradient of the wedge, an observable shading component would be introduced into the picture. This difficulty was overcome by having a stationary wedge sector

with the same density gradient as the minimum portion of the neutral density wedge inserted in the optical path with the slope of density variation reversed with respect to the wedge.

New RCA TV Projector designs include this control system as part of the projector. See Figs. 8 and 9.

Integrating the Control into Film Systems

General practice has been to integrate two or more projectors into a film pickup system. Several types of multiplexers are

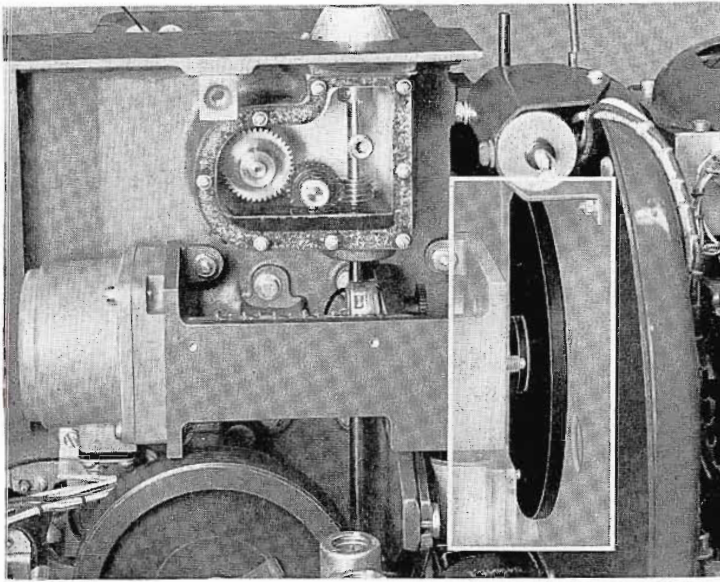

FIG. 8. Light-intensity control mounted in an RCA TP-6CC Projector.

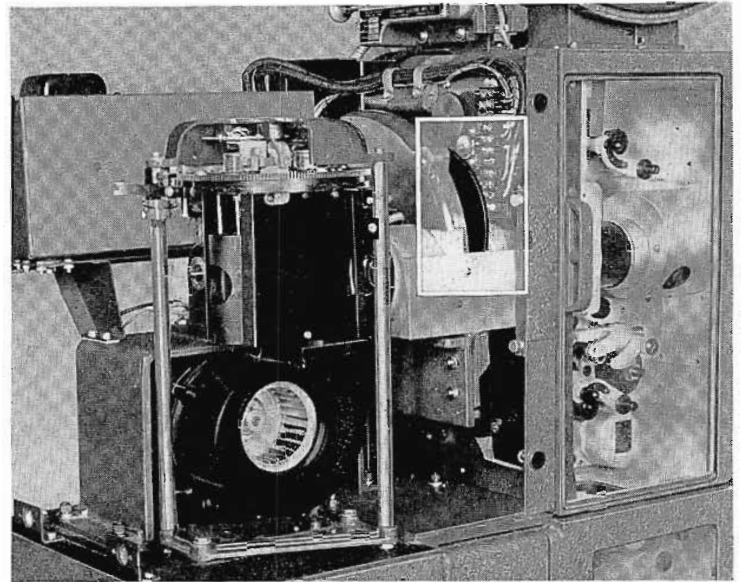

FIG. 9. Light-intensity control mounted in an RCA TP-35CC Projector.

available to perform this function of optical mixing. The RCA Multiplexer designed to work with this equipment performs the additional function of allowing switching between projectors from a remote point. It also operates the light-intensity controls from a single remote-control position, usually conveniently located at the camera control.

With this type of installation the gain control of the Three Vidicon Camera System actually is the light-intensity control of the projector. This and the master pedestal control are the only operating controls in the 3-V film camera system.

Other systems have been proposed and investigated. One of these methods uses a gain control for each projector. This has a distinct advantage over other systems in that it allows the setting up of each projector on an individual basis through a preview arrangement. The projector is set up at the proper output level by previewing. When switching from one projector to the next, using the multiplexer, it will come into the system at the proper level without the necessity of having to adjust the gain control. The main disadvantage of this system is that the video operator must select the proper control knob after switching to another picture source.

The chosen mode of operation uses one gain control knob to vary a number of projectors, see Fig. 10. Through relay switching provided in the multiplexer only one projector-light control at a time is varied from the camera-control position. This is

the projector designated as "On-Air" by the positioning of the optics in the multiplexers. The controls for the filter wedges on all other projectors are shorted to one end of the range, putting the filter wedges at maximum density. Thus, in switching between projectors, the filter wedge moves up from minimum light output to the control knob setting.

The basic advantage of this system is that the operator has but one master gain-control knob to handle, and switching of

the control of this knob is handled automatically by the multiplexer.

Conclusion

Although a relative newcomer to the field of television film pickup equipment, the vidicon tube has already proved itself in operation. Used in conjunction with this new light-intensity control it is to be expected that higher quality reproduction can be obtained from film pickup systems employing the vidicon.

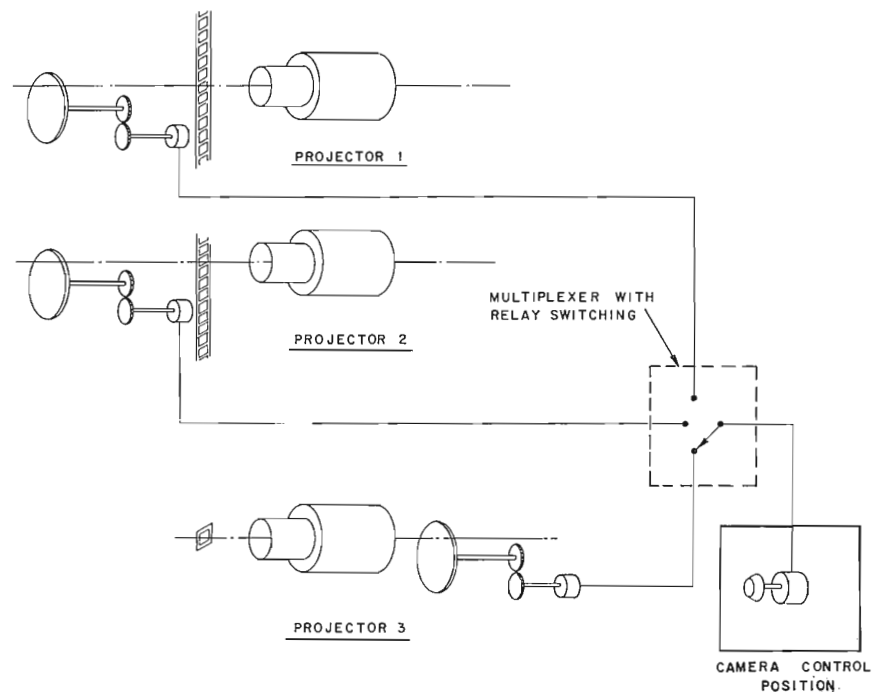

FIG. 10. Multiplexer system for varying light controls.

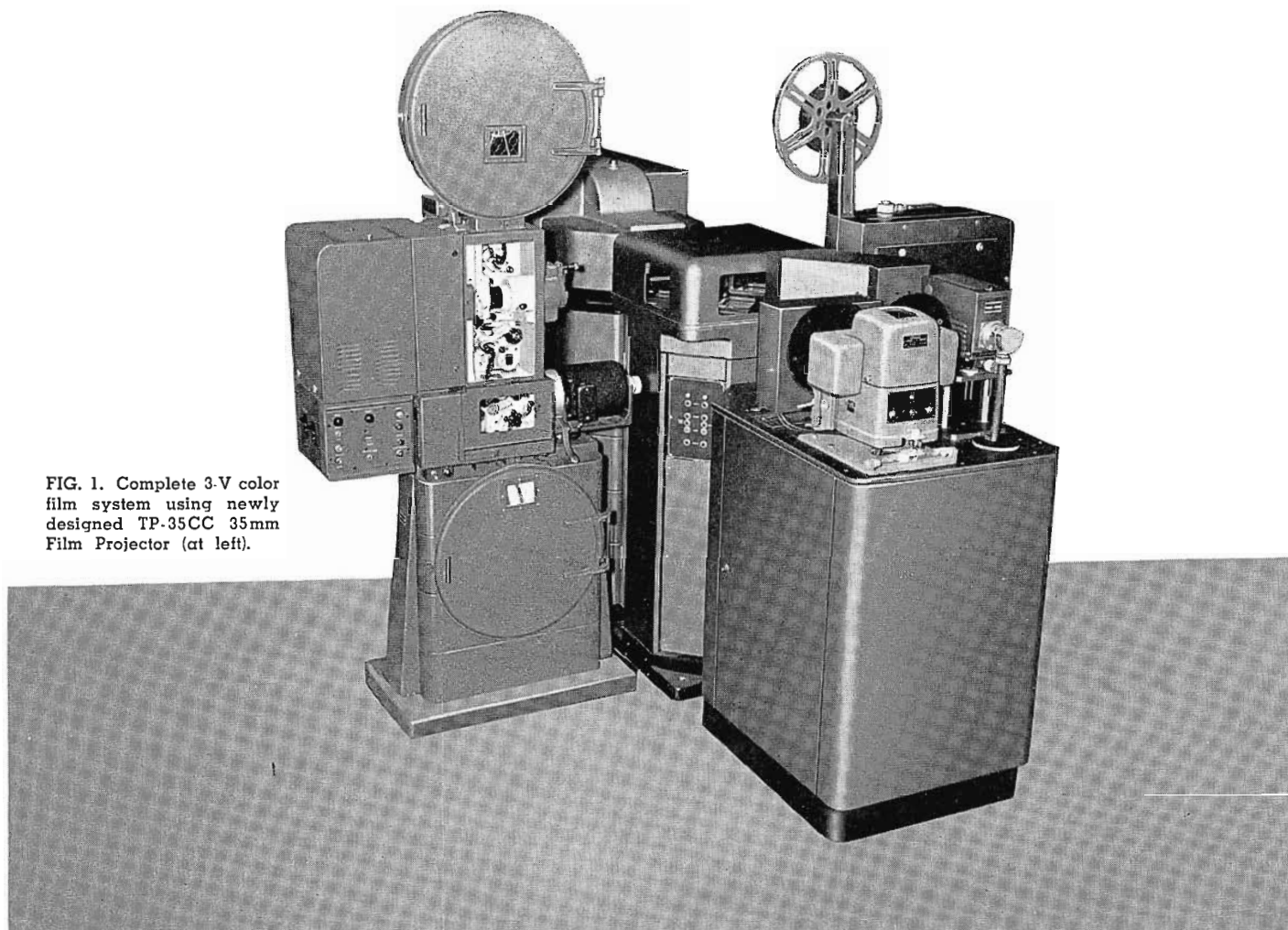

FIG. 1. Complete 3-V color film system using newly designed TP-35CC 35mm Film Projector (at left).

35MM INTERMITTENT MOTION PICTURE PROJECTOR FOR COLOR TV

This 35mm RCA projector has been designed primarily for television reproduction of color film with a three vidicon film camera. The camera uses three vidicon tubes, one for each of the primary colors of the film being transmitted. These vidicons "look" at a real image produced by the projector at a field lens. By the use of a separate lens on each camera and appropriate choice of dichroics and color shaping filters, each camera sees only the red, the green, or the blue components of the color picture. It is worthwhile to review the design requisites for a projector to be used in such a system (see Fig. 1) before proceeding to the discussion of the means used in obtaining the desired end results.

Monochrome Practice

It has been common practice in monochrome film telecasting to operate the projectors and the synchronizing generator, which controls the scanning circuits of the film camera, from the same 60-cycle power line, which permits one unit to be locked with the other so that an established phase

By
W. R. ISOM
 General Engineering Development
 and
W. F. FISHER
 TV Projector Engineering
 RCA Engineering Products Division

relationship may be maintained. With this tight lock, the projector shutter can be so phased that the light sensitive surface of the television pick-up tube is illuminated by the photographic image of the film that is being projected upon it only during the vertical blanking time of the television system or for a total not exceeding 8 per cent of the available light. (See Fig. 2.) To operate so as to utilize the full optical efficiency of the projector and with the photographic image on the film projected upon the sensitive surface of the pick-up tube without regard to its storage characteris-

tics has long been a dream. Until recently, the difference between the output signal level of a pick-up tube when it is scanned during the periods between the application of light (storage) and when it is scanned simultaneously with the application of light (non-storage) was so great that it was not normally used for both functions in the same application. Also, there was no available film equipment to allow the tubes to be used without reliance on their storage ability. Full non-storage, or simultaneous, operation makes rigid demands upon film handling machinery. Either continuous projection of the photographic image or film advancement during the vertical blanking time of the television system is required. Both are possible but until recently neither was available. Even now, to obtain high optical efficiency, both types of projectors require a degree of mechanical precision not commonly found in production equipment.

It is not surprising, then, that with previous TV projectors, the exposure of the photo-sensitive surface of the transducer to

light from the projector has been restricted to the vertical blanking interval of the scanning cycle. This restriction is necessary to prevent the appearance of a light application bar which results when the pick-up tube is illuminated with the image from the film during part of the scan period. This restriction limits the exposure time to something less than 8 per cent of a scanning field. It also limits the useful optical efficiency of the projector to the same figure. Under some conditions, with monochrome reproduction of dense film, the available light from the projector is marginal.

Color Television Considerations

For monochrome use, there is not complete agreement that this method of exposure during vertical blanking is fully satisfactory. But for color television, this method of operation with its inherent limitations and handicaps cannot readily be employed for film reproduction in a system operating under the present standards. The fundamental barrier to such an approach is the inability to use the 60-cycle power line frequency to synchronize the projector drive with the television scanning circuits. The reason is obvious. Both the horizontal and vertical deflection rates in a color system are derived from the crystal controlled sub-carrier frequency which is not an integral multiple of the line frequency. In addition, the limiting of exposure time to the vertical blanking period does not provide sufficient light for broadcast quality reproduction of color film. The additional attenuation due to the color correction filters and color separation dichroics of the system and the increased average density of color film require a projection system with greater optical efficiency.

Partial Storage and Non-Synchronous Operation

The vidicon pick-up tube has been found to have such a characteristic that it can be used as a storage and as a non-storage device in the same application. This characteristic, if certain conditions are met, permits freedom in projector speed. It is no longer necessary to lock the projector to the television system. The requirement is that no part of the signal electrode of the tube is to be scanned more than once per exposure to the photographic image of the film, provided this exposure is in the order of one-third of the field period. It has been determined that if light is applied to the signal electrode of the vidicon for a minimum of 30 per cent of each television field and in the same area, the vidicon scan will convert the image charge to an electrical

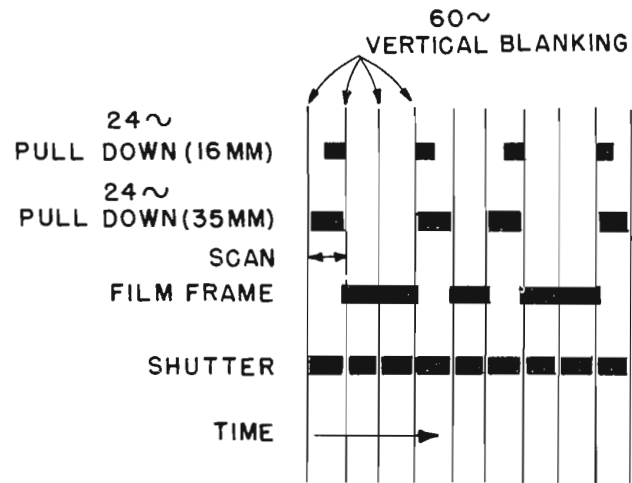

FIG. 2. Relationship between pull-down projectors, shutter, and scanning in prior television practice.

signal with no practical difference in output level between the periods of storage and non-storage. The application bar is thereby eliminated. With 30 per cent application time, the transition is less than 1 per cent in amplitude, which is below the threshold of visibility.

Thus, design criteria have been established for projectors which are to be used. The film advancing cycle, or pull-down time, must be sufficiently short to permit at least the minimum exposure of the signal electrode area of the vidicon required for non-synchronous operation. If the pull-down time can allow a longer application of light to the signal electrode, a large light reserve is available for use with films having wide density ranges.

60-Cycle Shutter Required

There is one other condition which must be met in order to operate the camera and projector in a non-locked manner. This is

concerned with the way in which the 24 frame motion picture rate is made commensurate with the 30 frame television system. Unless each scanned field has essentially the same exposure to light, both in timing and quantity, so that the tube acts on storage and non-storage in the same ratio through each field, an unacceptable flicker will be apparent in the reproduced picture. This is particularly bad if the signal electrode area of the vidicon is in part or in whole scanned twice after exposure to the projection of the photographic image. This means that the projector shutter must operate at 60 cycles per second. The required exposure is met and the undesirable effect is eliminated by holding one frame of film in the gate for two television fields or 1/30 second and the alternate frame for three television fields or 1/20 second. The average of 1/20 and 1/30 is 1/24, therefore 20 and 30 frames per second give a velocity average of 24 frames per second. A two-

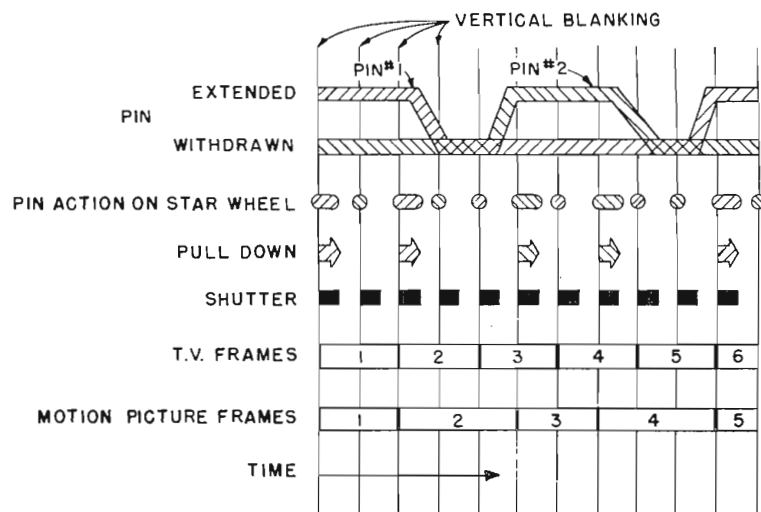

FIG. 3. Relationship between 35mm intermittent, shutter, and television scanning in the RCA vidicon method.

A "GENEVA"

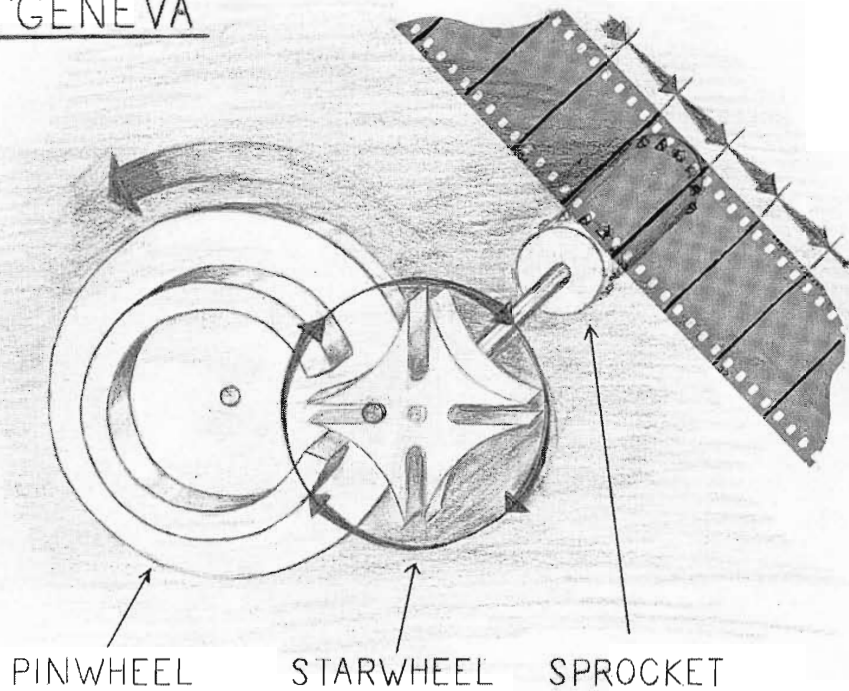

FIG. 4. Simplified diagram of a Geneva mechanism.

three intermittent cycle is required to obtain this relationship.

It is shown in Fig. 3 that with this arrangement the time required to show two film frames is identical with that required for five television fields. Fig. 3 also shows that the use of a 60-cycle shutter gives equal exposure to the signal electrode area of the vidicon for each scan.

The use of a two-three intermittent Geneva movement in TV film projectors is not new with this equipment. It has been used for some time in other RCA projectors. However, the method of obtaining this two-three relationship, as described below, does represent a novel approach.

The Intermittent

The Geneva movement type of intermittent has rendered such yeoman service to the motion picture industry that the word Geneva is synonymous with intermittent. Its familiar Maltese Cross could well be a badge of recognition for projectionists. This long record of highly satisfactory operation suggested that this mechanism should be used, if possible, for television service. Even laymen in the field know that one complete rotation of the pin wheel, or cam, produces a quarter turn of the Maltese Cross, or starwheel. (See Fig. 4.) The film advancing sprocket must have 16 teeth to advance the film one frame per cycle.

A preliminary survey of the requirements of the 3-vidicon color television film camera indicated, of course, that the usual

accommodation between the 24 frames per second rate of the motion picture system and the 30 frames per second of the television system was necessary. It is well-known that a Geneva can operate at 30 frames. The trick that suggested itself was to operate the Geneva at 30 frames but to modify it to pull film at 24 frames per second. A quick look at the arithmetic of the relationship between the motion picture frame rate and the television frame rate revealed that if one film advancing cycle of every five could be skipped or delayed for the period of one cycle of the thirty cycle rate, the Geneva could be operated at 30

frames per second speed and the film advanced at a twenty-four frames per second rate. (See Fig. 5.) Restating this in terms of the film, this means that every fourth frame of film is held in the gate of the projector twice as long as normally. Tests indicated that this would be satisfactory.

A second look at the arithmetic of the systems was taken to find the lowest usable multiplier. If the television system is considered as a basic 60-cycle system and the film system a 24-cycle system, then two and one-half is the multiplier. To make use of this relationship, it would mean that once every two and one-half cycles of the Geneva operating at 30 cycles per second, the film advancing cycle must be delayed one-half cycle. Restating this in terms of the film, it means that second frame of film is held in the gate of the projector fifty per cent longer than the first. This relationship is shown in Fig. 3.

Alternate Pin Technique

The translation of this requirement into mechanism was very apparent, due to the prior decision to use a Maltese Cross Geneva intermittent, if possible. Upon examination of a regular theater projector intermittent, it was seen that if two pins placed at 180 degrees apart were used instead of one and some provision made by which first one pin and then the other could be selected to actuate the Maltese Cross or starwheel, the Geneva could be used. Fig. 3 represents this sequence. Pin 1 engages the starwheel and advances the film one frame. The second time around, it advances the film to the second frame. By the time the pin is ready to advance the film to the third frame, it is withdrawn and the second frame remains in the gate until Pin 2, which has been extended while Pin 1 was being withdrawn, engages the star-

FIG. 5. Relationship of TV frames to film frames in the vidicon method.

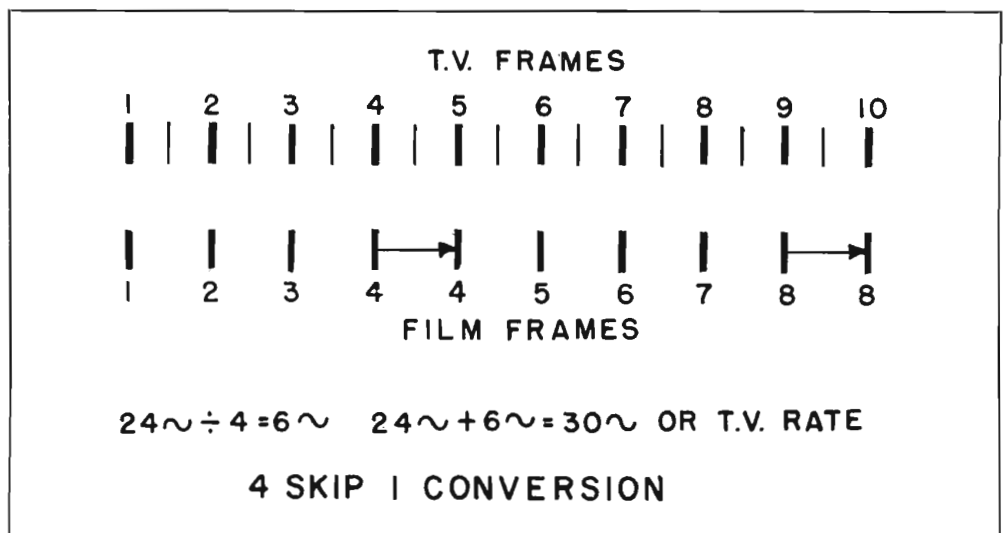

wheel one-half cycle later and advances the film to frame 3. Pin 2 advances the film to frame 4, and is withdrawn. Pin 1, now again extended, advances the film to frame 5 which is the beginning of a new sequence. Four frames of film have served for five frames of television information.

An analysis of the pin action to accomplish this sequence of operation shows it to be very simple and well adapted for cam manipulation. Each pin in succession is extended to actuate the starwheel twice and then withdrawn while the other pin takes over and does the same. The cam required is simple, having two rises and two dwells. The repetition rate is also relatively low. Each pin completes a period of operation every five cycles of the Geneva or six periods a second. The cam, then, rotates at 360 revolutions per minute. However, the pins are in the pin wheel which rotates at 1800. If the cam is to operate the pins directly so as to avoid linkages, the difference in speed between the pin selector cam and the pin wheel must be 360 rpm. This difference can be either positive or negative. Because of other design considerations, the slower speed, 1440 rpm instead of 2160, was selected.

The total time available for withdrawing and extending the pins is three-fourths of a Geneva cycle. There are two pins 180 degrees apart and if it should be necessary to withdraw and extend the pins simultaneously, only one-fourth of the Geneva cycle would be actually usable for this purpose. Converting this in terms of degrees of rotation of the pin selector cam gives 18 degrees. The cam design is not complicated if each pin is withdrawn directly after its duty cycle is completed and extended just prior to its actuation of the starwheel. The time available permits a 54 degree rise of which the design actually uses 50 degrees. This affords an easy tolerance for the phasing of the mechanism. The rise is so gentle that the operation is smooth.

Safety Locks

This completes the modification of a standard Maltese Cross Geneva movement so that it can be operated at 30 cycles a second while advancing film at 24 frames per second. However, certain safeguards are necessary to insure reliable operation. Particularly, the Geneva lock is involved. The segment of the lock ring beneath the pins must be opened to permit the intermittent to cycle. When the pin is withdrawn, the starwheel is not locked at this point. Especially during threading or starting, there is some likelihood that the star-

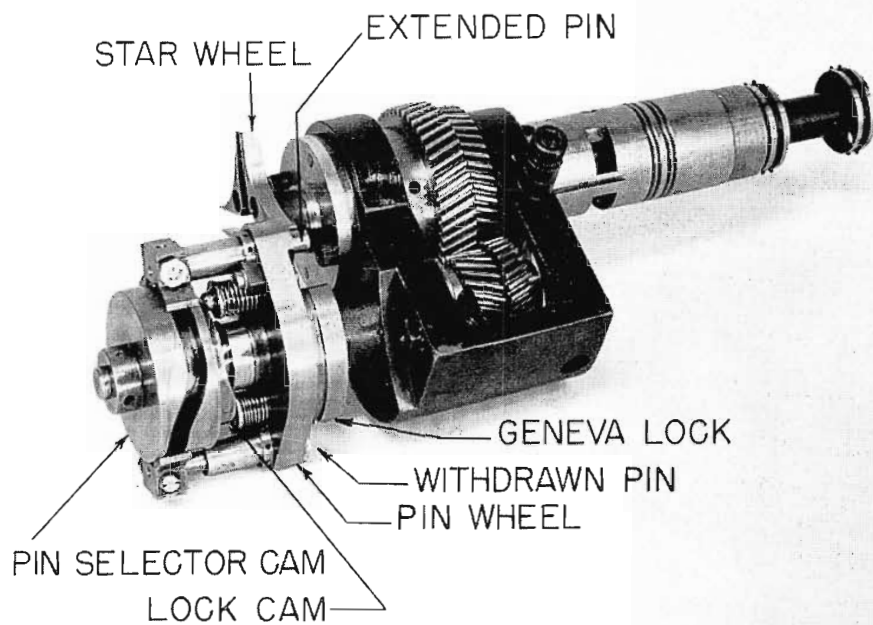

FIG. 6. Overall view of complete intermittent.

wheel might be rotated and the movement jammed. To prevent this, safety locks were incorporated, which are actuated by a cam. Although the pin selector cam could be used for this purpose, with linkages to effectively shift its phase 180 degrees, the design was considerably simplified by using a second cam.

Overall views of the completed intermittent are shown in Figs. 6 and 7. Notice

that the pin selector cam is to the left. The lock actuating cam is identified by the spring loaded followers. The pin wheel has one pin extended and the other withdrawn. Fig. 7 shows the safety lock beneath the withdrawn pin. It also shows the manner of driving the pin selector cam by a shaft within a shaft from the pin wheel driver idler gear. The largest gear is the pin wheel driver; the smallest is the driven pin

FIG. 7. Close-up of intermittent showing gear mechanism.

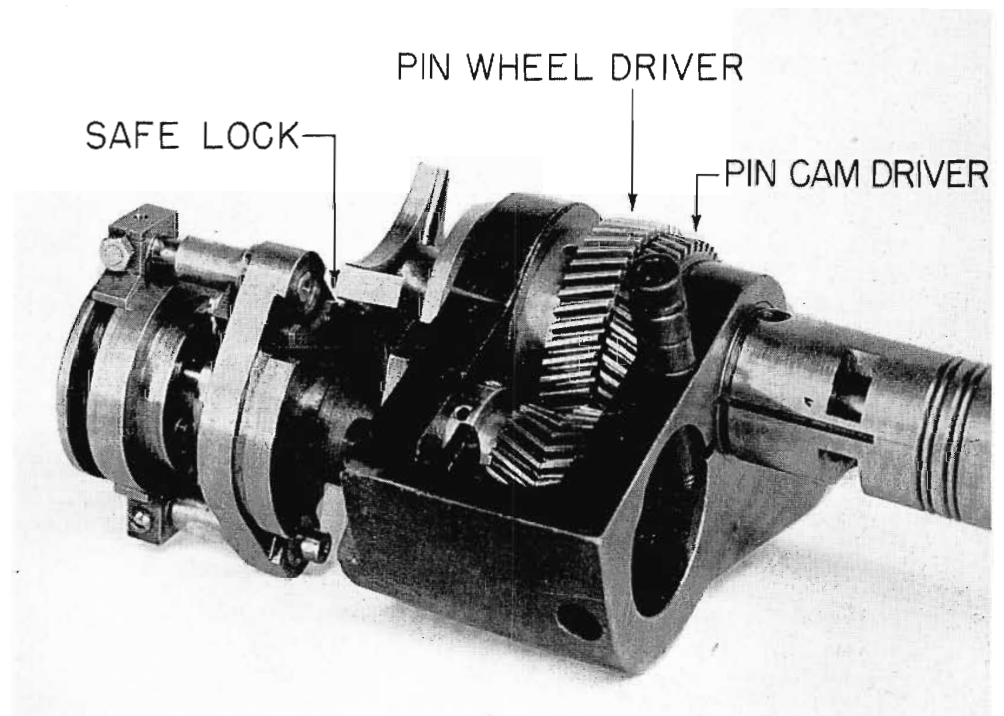

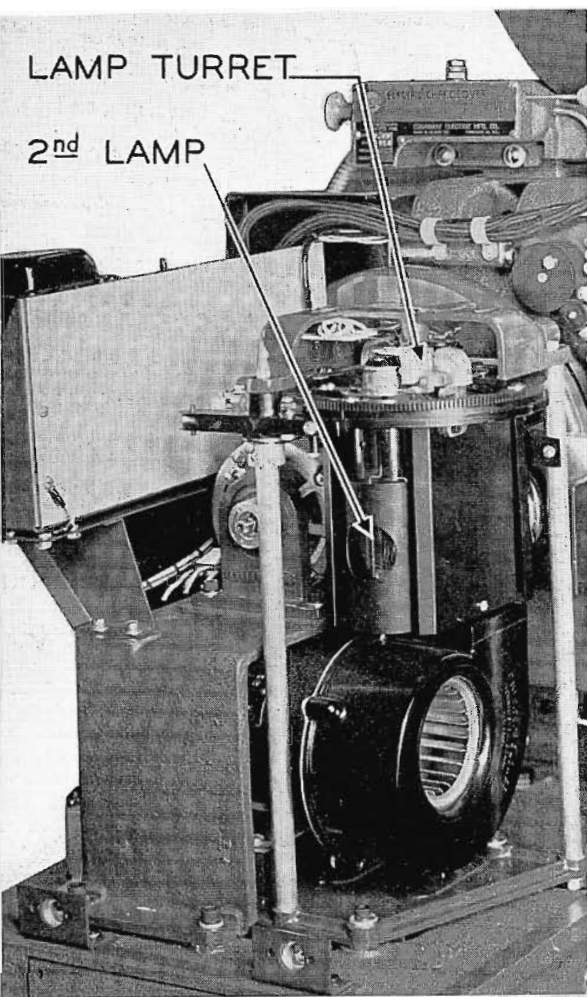

FIG. 8. Close-up of quick-change lamp house.

wheel gear. Beside this set is the main driver, and the driven gear for the pin selector cam. The two larger driver gears run at the same speed. The driven gear for the selector cam runs 360 rpm slower than the driven pin wheel gear. The entire unit is lubricated by a continuous bath of oil.

Significance for TV

The modification has made the Geneva intermittent much more flexible and adaptable to many of the new uses that have been introduced as the result of television, the outdoor theater, and the wide screen theater. This particular modification for television use establishes a four-pointed star Geneva as a basic 60-cycle device. It is possible to use it with either storage or semi-storage type of film pick-up tubes. Its high shutter efficiency—46 per cent at 60 cycles—permits long exposure of the sensitive surface of vidicons, image orthicons and iconoscopes to the projection of the photographic image on the film during scanning. Compared to the 8 per cent maximum efficiency of the vertical blanking time exposure technique, this gives almost six times as much light.

Thus, the peak output signal of the pick-up device is available for processing. This increased light output is necessary for the reproduction of film in full color

over television using the 3-vidicon system. The large light reserve insures a color video signal with a high signal-to-noise ratio. The non-synchronous operation is a "must" for color television.

In addition to color television, the importance of this projector development for monochrome use with a 1-vidicon system must not be overlooked. The high light efficiency of this projection system makes possible superb signal-to-noise ratio. A ratio of 300 to 1 can be obtained. With aperture correction sufficient to obtain essentially 100 per cent response at 350 lines, a ratio of 100 to 1, or 40 db, can be realized. The freedom from noise coupled with the freedom from synchronous operation establishes this projector development as quite significant for monochrome use, particularly in eliminating roll-overs when

a quick-change lamp house is used (see Fig. 8) so that a new lamp is put in operation within less than one second in case of failure. This is accomplished automatically whenever the filament current of the lamp in use is interrupted. Hence lamp failure is no longer a source of lost air time. This feature also permits a lamp to be used to the full extent of its life, since there is no need to change a lamp in anticipation of its failure.

The second element in the optical system that has received full attention because of the television application for which this project is intended is the condenser optical system. (See schematic, Fig. 9.) The condenser optics have been tailored to fit this projector. The first concern, of course, was for a flat field and this has been very well achieved.

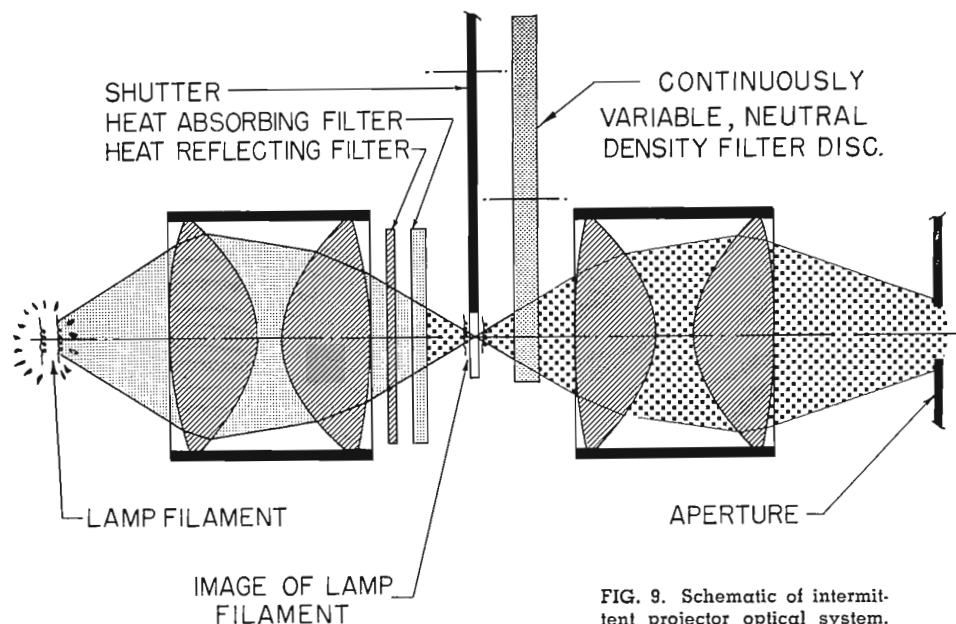

FIG. 9. Schematic of intermittent projector optical system.

switching between network and local pick-ups. Of course, the flashing of the pick-up tube during vertical blanking is easily possible if desired.

Optical Elements

A 1000-watt incandescent lamp of the pre-focus base-up type is used as a source of illumination. The convenience of a tungsten lamp plus the non-blackening characteristic of the base-up construction makes a more than satisfactory light source for color television film work. The color temperature of this lamp is quite stable over a long time period, maintenance is simple, and life very satisfactory. In this application, as in other projectors developed with television use primarily in mind,

In addition, the condenser optics are designed to provide for other conditions. Because this machine will be used most frequently with costly color film, with almost six times more light available for transmission than is commonly used for monochrome TV, it was deemed wise to introduce into the condenser a heat filter in order to completely protect the film. This is accomplished by the use of one heat-reflecting and one heat-absorbing element. These prevent the passage of heat transmitting infra-red rays from the lamp to the film. The effectiveness of this filter is demonstrated in its ability to hold a single frame of color film in the projector gate with the lamp at full brilliance, indefinitely. This is positive assurance that the film is

not endangered by heat from the light source. Furthermore it is useful and rather important to be able to project a single frame in television operation.

Space is provided in the condenser system for the light interrupting shutter. As previously noted, it is important in using a 3-vidicon system of color pick-up that no portion of the target be scanned twice after exposure to light. It is also well known that projector shutters do not rotate at constant speed. Under the worst conditions of operation this flutter of the shutter has been known to produce a tell-tale bar across the displaying kinescopes. In order to design out of the projector all possibility of this fault, the shutter cuts through the light path in the condenser in the plane of an image of the filament. Since all points of the film aperture are illuminated by each point of the lamp filament, this arrangement insures that the shutter operation is variable density or in the manner of an iris. This elimination of a sharp shutter cut-off permits a wider tolerance on the speed constancy of the shutter than is needed.

The third important special accommodation that the condenser system provides is space for a variable neutral density filter. The advantage of having a high optical efficiency for the projector is thus realized in the ability to use film of wide density ranges. In effect a continuously variable neutral density filter disk is placed into the condenser optical path. The control of the transmission efficiency of the condenser system is located remotely on the video control panel. This permits the maintenance of reference video levels while accommodating wide variations in film density. The objective is a fully corrected $f/1.9$ 6-element lens. The speed of the system is fully adequate to insure noise free operation of the vidicons.

Other Elements

In order to achieve the utmost in reliability, the drive is a 3-phase, 220-volt, 60-cycle synchronous motor with a d-c field. The separate shutter-drive motor is phase sensitive and permits rotational phase lock to the drive motor in the most simple and reliable manner without interlocks.

Special attention has also been given to reels and magazines provided for this projector. In many instances, color film has greater thickness than black and white film. At times it has been inconvenient if not impossible to load a standard 2700-foot reel with the film required for a 30-minute color television show. The reels and magazines supplied with the projector meet this requirement. The same sound repro-

ducing head that is used with theater type projectors is a part of this projector. The complete machine is shown in Fig. 10.

The projector has been made strictly compatible with the television system. The projector has an intermittent which permits high optical efficiency so that color film may be used successfully. The projector has a special condenser optical system that makes possible satisfactory operation with films of great density ranges. The drive motors have been selected for their reliability and the other accessories for their special application and high performance. This quick review of the require-

ments for the reproduction of color film with the 3-vidicon film camera reveals how completely they have been met in the projector design described above.

References

- H. N. Kozanowski, "3-Vidicon Color Film Camera", *BROADCAST NEWS* No. 79, pp. 8-15, May-June 1954.
- R. G. Neuhauser, "Vidicon for Film Pick-up", *Journal of the SMPTE*, Vol. 62, No. 2, pp. 142-152, February 1954.
- Color Transcription*, and other sections, Final Report of Panel 11A, NTSC, November 10, 1953.
- J. G. Jackson, "A 60-Degree Geneva Intermittent Movement", *International Projectionist*, Vol. 30, No. 2, February, 1955, pp. 7-26.

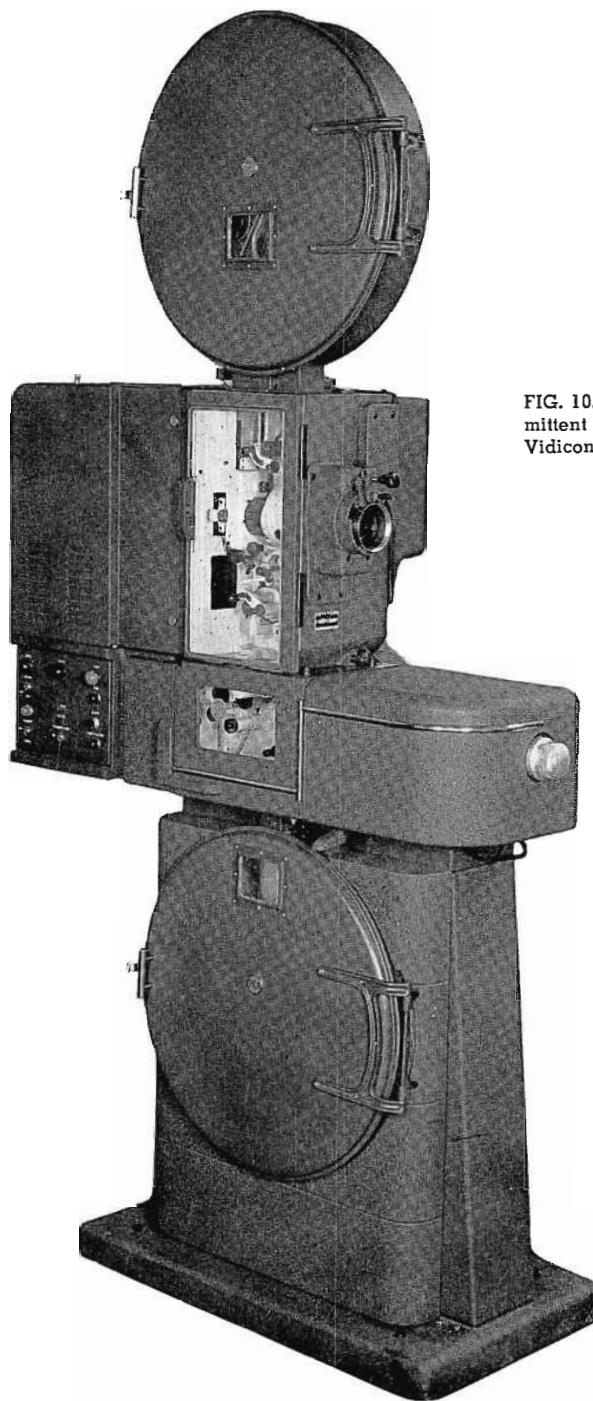

FIG. 10. The RCA 35mm intermittent projector for use with Vidicon Film Camera Systems.

TELEVISIONING LARGE AND SMALL OPAQUES AT WMUR-TV

By **CHARLES F. HALLE**
Chief Engineer
WMUR-TV, Manchester, N. H.

A new system for televising opaques through an RCA TK-21 Vidicon camera and TP-12 multiplexer has been devised.

It was desired to provide a method of televising 8 by 10 inch facsimile pictures for a newscast, without turning on a studio camera. At the same time it was felt that 3 by 4 inch balop pictures should also be utilized. The optical and mechanical problems involved in being able to reproduce both size pictures on one machine were at first thought to be quite complicated, until

it was realized that most of the elements required were already present in the vidicon and multiplexer.

Provision is already made in the vidicon multiplexer for use of a Telop. This consists of a fixed mirror, field lens, and sliding mirror. Accordingly, an old 9 inch lens from an unused projector was mounted in front of the multiplexer opening. The material to be televised was placed on a card, upside down, on a movable easel in front of the lens, with two 300-watt reflector floods as a light source. By moving the easel back and forth, any size card from 3 by 4 to 8 by 10 inches can be accommodated. The lens was mounted in a wooden block and

for focusing, the whole assembly slides back and forth on two ½ inch steel rods mounted on the multiplexer. The two reflector-flood lights were mounted on goose-necks so as to enable them to be more easily adjusted to compensate for different program material.

As can be seen from the accompanying photos, the whole assembly is very simple and easily constructed. The results obtained were excellent, and enabled WMUR-TV to do a late evening newscast utilizing facsimile pictures without using a studio camera. It also is useful in putting random sized artwork on the air quickly without waiting for slides to be processed.

This device utilizes a 9-inch lens mounted in front of multiplexer opening, in conjunction with a movable easel and 300-watt lights.

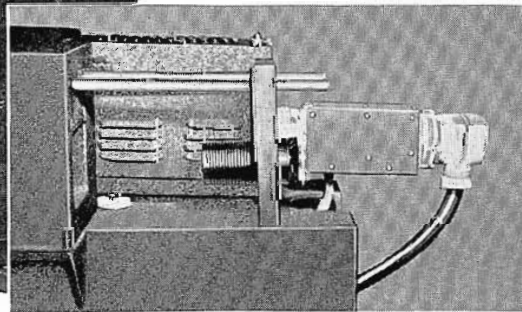
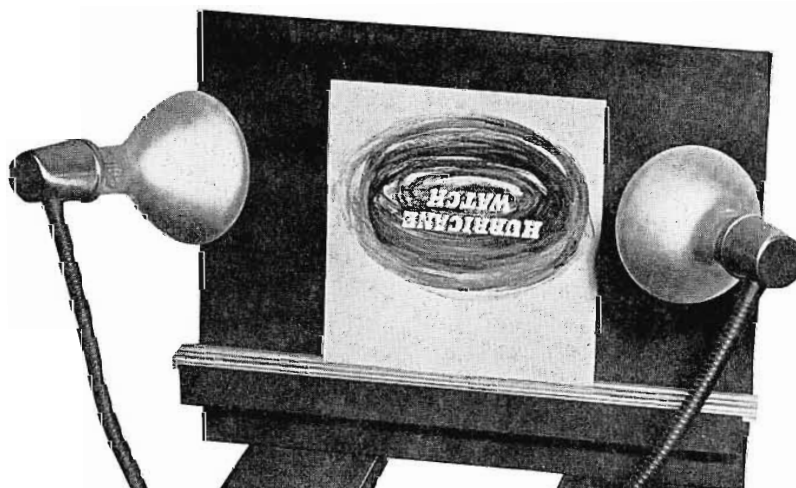

The 9-inch lens is mounted in a block of wood, which slides back and forth for focusing.



How to give your TV commercials a "COMPETITIVE EDGE"

Television audiences today are "conditioned" to many of the brilliant motion picture techniques now also used in TV productions—and they like it! Take away smooth switching—fades, lap dissolves, and transitions they are used to watching—and commercials look flat, dull, and jerky. Add these effects and the same presentations take on sparkle and dimension. In short, *your commercials have a "competitive edge"!*

Are your presentations out of date?

Are your commercials limited to "direct switching" from scene to scene—or simple fades to black—because an elementary video switcher is used? If so, the sponsor is not getting the full benefit of all the programming ingenuity that could be at his disposal.

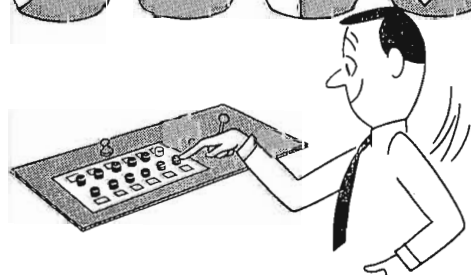
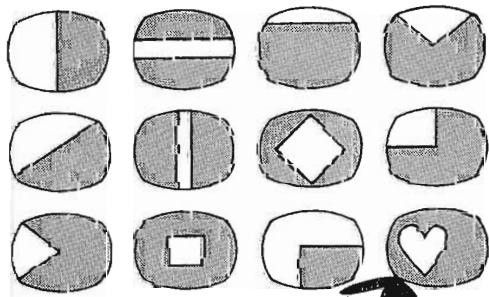

How to make commercials "live"

Modern video switching with special effects is your answer. With it, program directors can produce a variety of attention-getting effects in an instant; horizontal and vertical wipes, horizontal and vertical splits, controllable inserts, wedges, and other optical effects. You push the button for whatever you want—and insert the effect wherever you want it. Up goes audience interest. And up goes sponsor satisfaction.

Which Switcher for you?

RCA has a video-switching system to meet the specific requirement of each and every station.

For example, RCA's TS-5A is ideal for small studio operations—provides fades, lap dissolves, super-positions—handles 5 signal inputs.

Type TS-11A is designed for maximum utilization of facilities—for any size operation. It provides all facilities—includes a

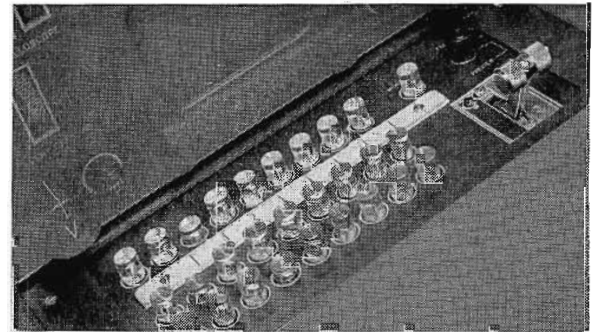

TS-11A VIDEO SWITCHER

program transfer switch for previewing fades, lap dissolves, and special effects. Studio programs can be rehearsed while network or film is "on-air."

Type TS-20 is a relay switching system for the larger installations. It is the ultimate in flexibility for modern programming. You can begin with as few as 6 inputs and 2 outputs and build up to a maximum of 12 inputs and 6 outputs.

Special effects equipment

Twelve attention-getting effects at your finger-tips . . . You push the button for the effect you want. You swing the "control stick" and put the selected effect wherever you want it. Simple, inexpensive—requires no complicated equipment or extra cameras. Any one of the above switchers coupled with this special effects equipment can give you the extra sales "edge" you want.

For expert help in planning the right video switching and special effects system, call your RCA Broadcast Sales Representative.

Ask
the Engineer
—he knows



**RADIO CORPORATION
of AMERICA**

ENGINEERING PRODUCTS DIVISION • CAMDEN, N.J.

In Canada: RCA VICTOR Company Limited, Montreal

It's Here! RCA's Production

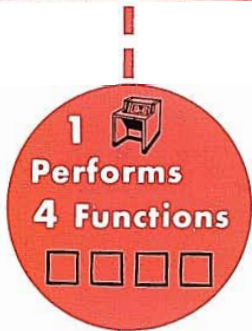

MORE EFFICIENT

"All-in-one" Processing Amplifier combines the signal processing functions of previous channel amplifier, gamma corrector, shading generator, and monitor auxiliary.

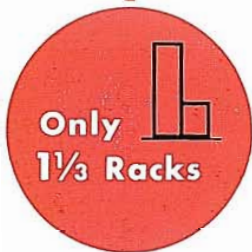

COMPACT

The new equipment utilizes only 100 inches of rack space; can be mounted in only 1 1/3 racks for efficient, compact installation.

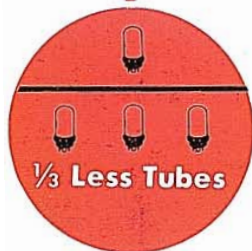

LOW OPERATING COST

Requires half the ac power needs of conventional equipment and permits elimination of 50% of former dc power supplies. Uses 9 less rack-mounted units, and 134 fewer tubes — conservatively operated for extended life.

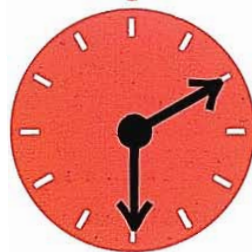

FAST SETUP

Centralized controls minimize setup time, require but a single operator for control functions. In addition, over-all stability, improvement in camera performance and picture quality are assured.

No need to wait any longer for *production* live color TV equipment! RCA has it now... a complete new TK-41 Color Camera chain with new all-in-one Processing Amplifier, which combines four major functions in one. It not only provides important savings in components, floor space and operating costs, but assures highest quality at lowest expense.

This is the complete color camera TV equipment that television stations are now using in their swing to color, or in expanding their color facilities. For complete technical information, call your RCA Broadcast Sales representative. In Canada, write RCA VICTOR Company Limited, Montreal.

RCA TK-41 TYPE COLOR CAMERA

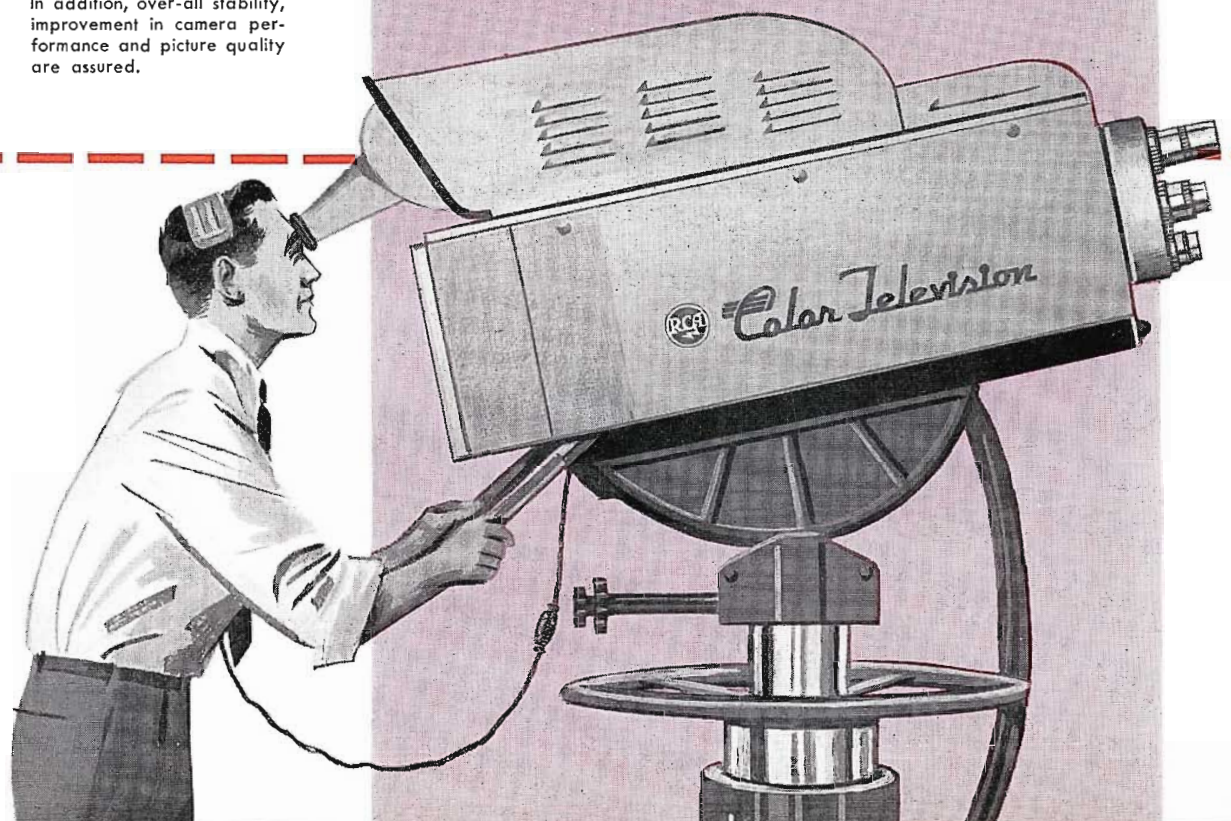

COLOR CAMERA TV EQUIPMENT

... with the revolutionary all-electronic
processing amplifier

which combines all
signal processing
functions in a
single chassis.

12-Page Descriptive Brochure
Available on Request.

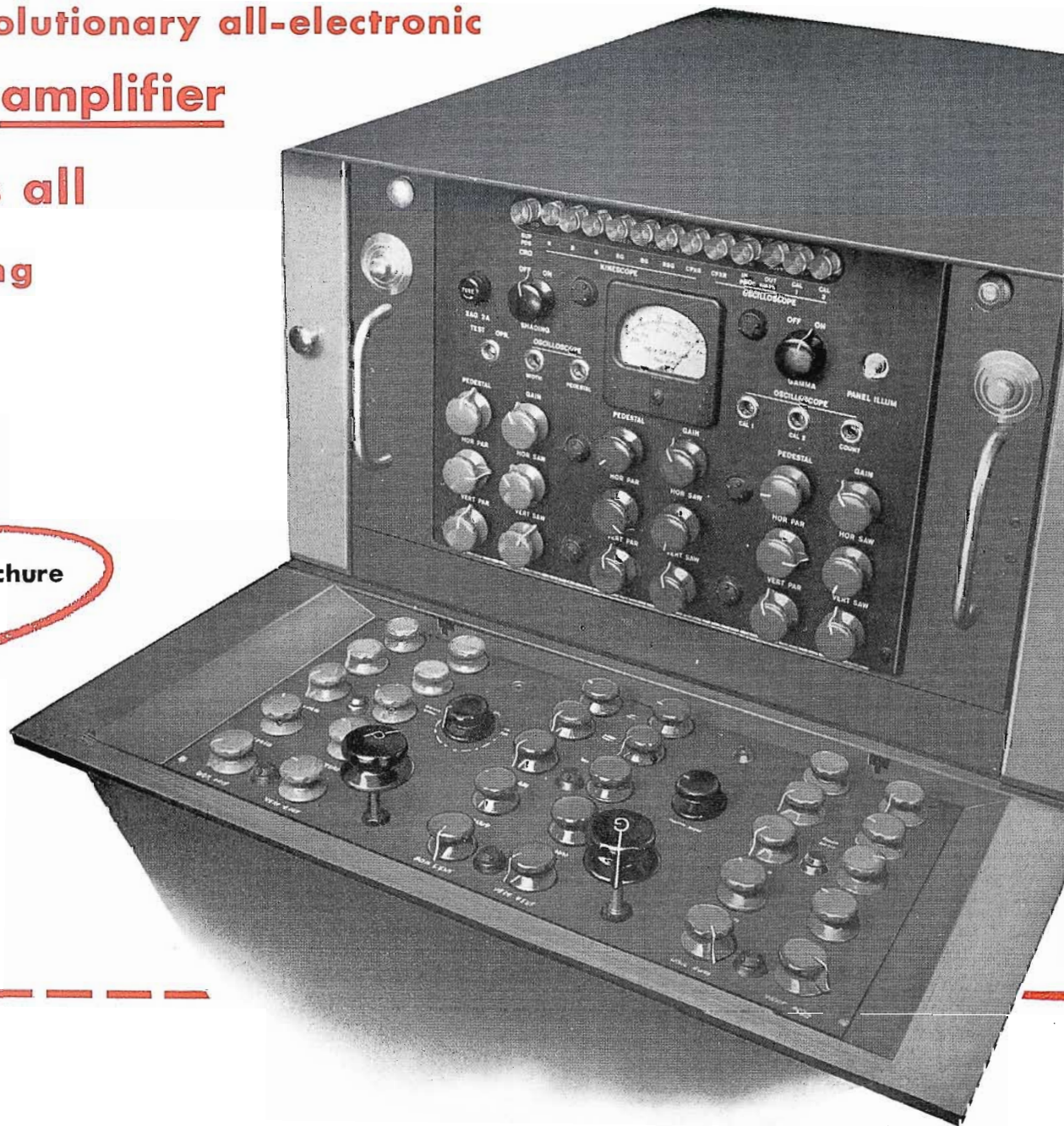

RCA Pioneered and Developed Compatible
Color Television

View of
Processing
Amplifier



RADIO CORPORATION of AMERICA
ENGINEERING PRODUCTS DIVISION
CAMDEN, N.J.

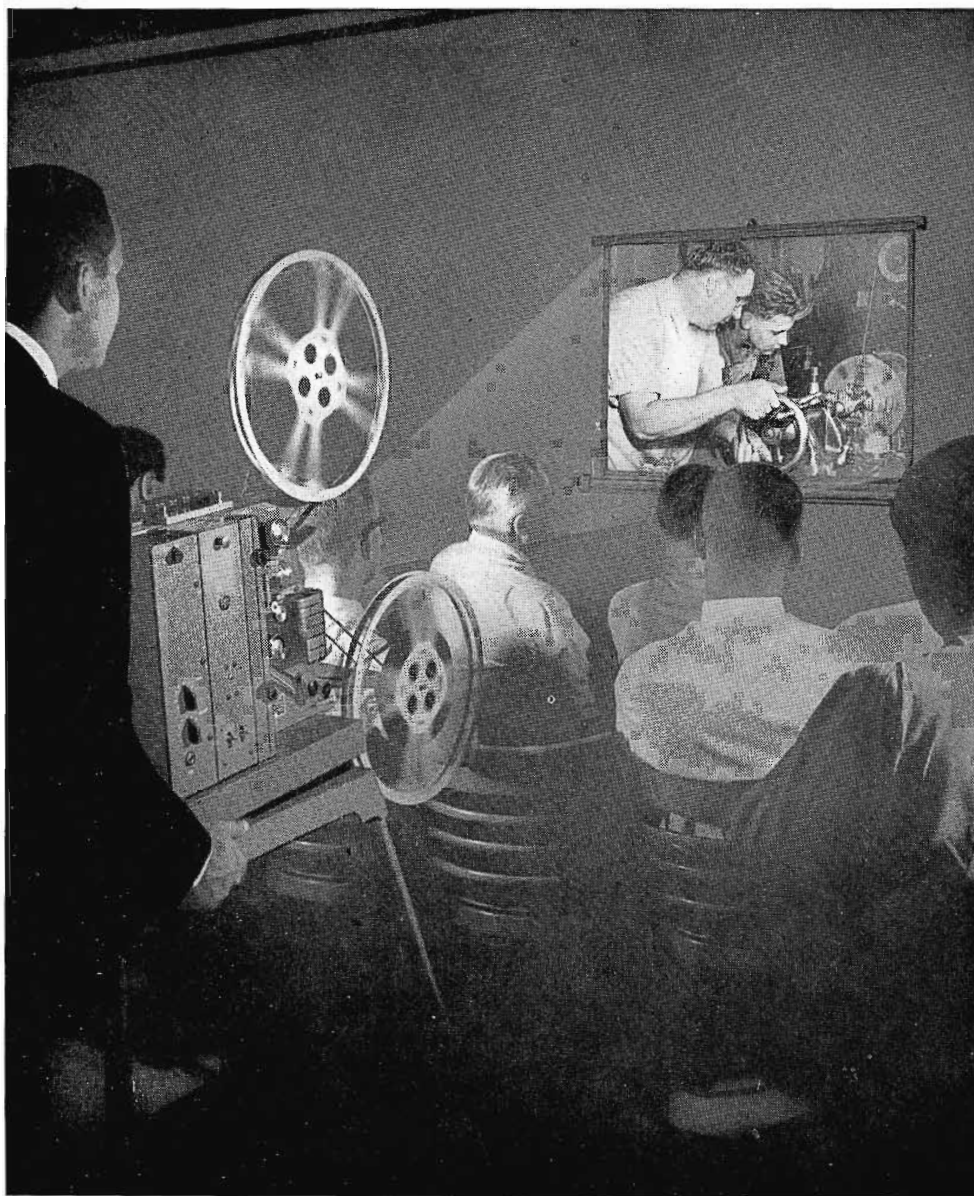

How to make job training a good show ...with an RCA 16mm Film Projector!

Industrial training directors know that sound motion pictures teach quickly, effectively, thoroughly. And there's nothing better than an RCA 16mm Film Projector to deliver bright, steady pictures . . . clear, lively sound without distracting operating noise.

You can have a picture on-screen in minutes—anywhere an audience can gather. These portable RCA Projectors are engineered for easiest operation, compactness, unflinching performance.

No wonder so many businesses today use RCA Projectors for job instruction (as shown above), for work simplification,

employe indoctrination . . . for selling in the field, staging sales meetings, making impressive presentations. Hundreds of schools, churches, hotels and civic groups also have selected RCA 16mm Projectors—manufactured to the same exacting standards as RCA's famous professional line of theatre projection equipment.

For free booklet on the profitable applications of RCA 16mm Film Projectors, or for information on other RCA electronic products, write to RCA Engineering Products Division, Dept. WB-163, Bldg. 15-1, Camden, New Jersey.



The world's best name for quality in electronics

RADIO CORPORATION of AMERICA

Choose RCA electronic products for better business!

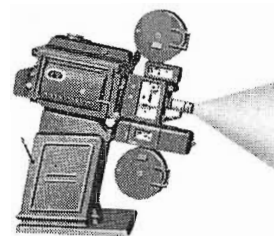

RCA Theatre Equipment is increasingly the choice of the nation's motion picture exhibitors. The complete line includes everything for the modern theatre . . . both outdoor and indoor . . . from projectors to carpeting.

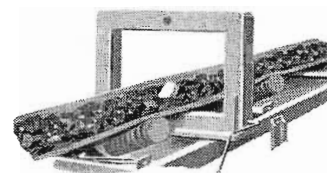

RCA Metal Detector finds metal particles (magnetic and non-magnetic) in rock products, foods, plastics, textiles and other belt-conveyed materials. Protects machinery from damage and product from foreign bodies.

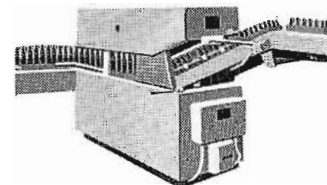

RCA Beverage Uncaser automatically unloads empty bottles from cases, loads bottles onto washer. Adaptable to all washers, many bottle and case sizes. Increases bottler's efficiency, reduces breakage.

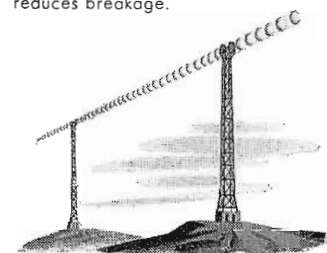

RCA Microwave provides point-to-point communication by beaming radio signals between relay stations. For pipelines, railroads, utilities, government agencies, and other qualified users.

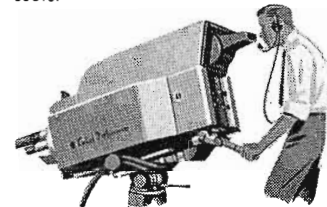

RCA TV Cameras are used today in a large number of the nation's television stations. They are part of a complete line of very high quality equipment which RCA supplies for radio and television broadcasting.

For Export . . .



NEW RCA SSB-1 TRANSCEIVER OPENS A NEW ERA IN LOW-COST HF COMMUNICATION

COMPACT NEW RCA SSB-1 is only 24½" high, 22½" wide, 16½" deep. Ideal for simplex and duplex radio-telephone and radiotelegraph services.

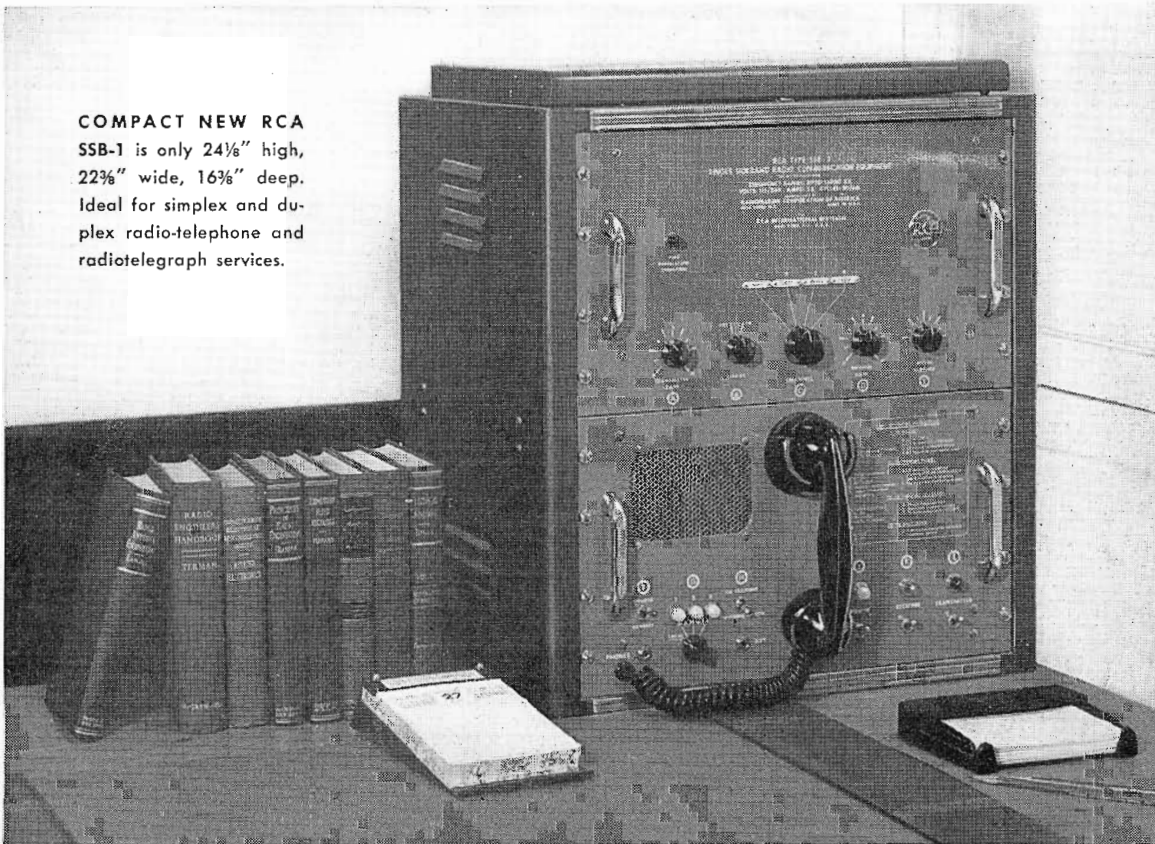

FOR THE FIRST TIME in HF Telecommunications, RCA is making available the proved advantages of single-sideband communications . . . at a cost everyone can afford. This technique of communications has been used in intercontinental telephony since 1926, but never before has it been offered at such a low price.

Another advantage that will be welcomed by users of high frequency telephony and telegraphy is the extremely simple operation of RCA's new SSB-1. And of course, the SSB-1 offers you the practicality and dependability that have made RCA communications equipment world-famous. For full details, see your RCA distributor or write for free booklet today!

THE 60-WATT SSB-1 GIVES YOU THESE 6 BIG FEATURES:

1. **SPECTRUM CONSERVATION**—Uses less than ½ frequency bandwidth of conventional AM.
2. **HIGHER EFFECTIVENESS**—60-Watt SSB-1 is equal to 500-Watt conventional AM Transmitter.
3. **REDUCTION OF DISTORTION AND INTERFERENCE**—50% less interference than conventional AM.
4. **VERSATILITY**—Four channels, telegraphy and telephony.
5. **SIMPLICITY**—Does not require a technical operator.
6. **ECONOMY**—Low initial and operating costs.

FREE

Send for booklet giving full details of the new RCA SSB-1. Write:



TRADEMARK(S) & REGISTERED
MARCA(S) REGISTRADA(S)



RCA INTERNATIONAL DIVISION
RADIO CORPORATION of AMERICA
30 ROCKEFELLER PLAZA, NEW YORK, N. Y., U. S. A.

NEW...

RCA

All New Type

10,000 WATTS



With High Quality Sound Channels!

*Good Color
Performance
Depends on These
Specifications*

- Power Output... 1 Watt
- Differential Gain (Linearity)... 0.5 db max.
- Differential Phase Distortion (at 3.58 mc)... less than 1%.
- Amplitude Frequency Response ... Flat within .3 db 60 cycles to 6 mc.
- Synchronizing Signal Compression... Negligible.
- Low Frequency Square Wave Response . . . Less than 1% tilt at 60 cycles.

For descriptive literature on this newest of microwave systems or help in planning your microwave setup, consult your RCA Broadcast Sales Representative.

MICROWAVE

High-Power

TVM-1A designed for Color TV

(Best for Monochrome, too)

ERP AT 7000 MC

The TVM-1A is the only microwave equipment designed specifically as an integral part of a complete color TV system . . . from color originating equipment to color receivers. Whether you're a monochrome or color user, you will appreciate these special advantages:

HIGH POWER

An increase of 10 in transmitter power and about 3 db in receiver sensitivity offers 20 times the power margin of the popular RCA TTR-TRR series of microwave equipment. This means greater operational reliability with an increased fading margin.

SOUND DIPLEXING

Included in the TVM-1A system is high quality audio channel for the simultaneous transmission of sound along with picture

information. This sound channel is well within FCC requirements for a studio-to-transmitter link (STL).

TRANSMITTER AUTOMATIC FREQUENCY CONTROL

Transmitter AFC offers exceptionally good frequency response and highest stability. It is especially useful in multihop operation with unattended repeater stations.

TRANSMITTER PICTURE MONITORING

This facility assures an actual high quality "air" signal. It simplifies trouble shooting procedures and is also extremely useful in the operation of unattended repeater stations.

RCA Pioneered and Developed Compatible Color Television



RADIO CORPORATION of AMERICA
ENGINEERING PRODUCTS DIVISION

CAMDEN, N.J.

Order Now...

Directional characteristics of the BK-5A Microphone about the vertical axis.

RCA's NEW BK-5A UNIAXIAL MICROPHONE

Today's most versatile sound pickup unit

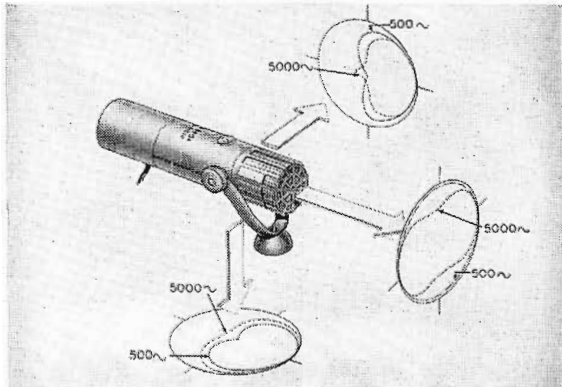

DIRECTIONAL CHARACTERISTICS about the major axis. At low frequencies the pickup pattern is a true cardioid. At 5000 cps and above, the pattern becomes fan shaped.

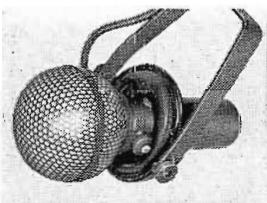

BK-5A Microphone with Wind Screen and new, improved Boom Mount.



BK-5A mounted on Type 91-C Desk Stand.

The RCA Uniaxial Microphone meets the increasing need for a high-quality ribbon microphone with superior directional characteristics. This microphone is truly uniaxial; its direction of maximum sensitivity has been designed to coincide with the major axis of the microphone. The BK-5A is built for simple and sure handling when mounted on a boom. Its improved shock mount effectively isolates microphone from

boom support and does not itself generate any noise, thus assuring noise-free handling. Sensitivity to wind is also reduced. Premium performance, classic styling and ease of handling will assure years of successful application.

Ask your RCA Broadcast Sales Representative for complete information. In Canada, write RCA VICTOR Company Limited, Montreal.

FEATURES OF RCA TYPE BK-5A MICROPHONE

- ★ Uniaxial feature simplifies microphone and camera placement
- ★ Improved directional characteristics with wide pickup angle
- ★ High quality reproduction to 15,000 cycles
- ★ Small and lightweight for TV boom operation
- ★ Sturdy construction with blast filter to reduce effect of violent noises
- ★ Exceptional shielding for operation in high hum fields
- ★ Wind screen available for outdoor use or fast-panning shots
- ★ No rubber bands to replace, with new shock mount
- ★ Improved longer-life flexible cable

Pioneers in AM Broadcasting for Over 25 Years



**RADIO CORPORATION
of AMERICA**

ENGINEERING PRODUCTS DIVISION

CAMDEN, N. J.

Report from Canadian Broadcasting Corporation

**33,738
HOURS
ON-AIR**

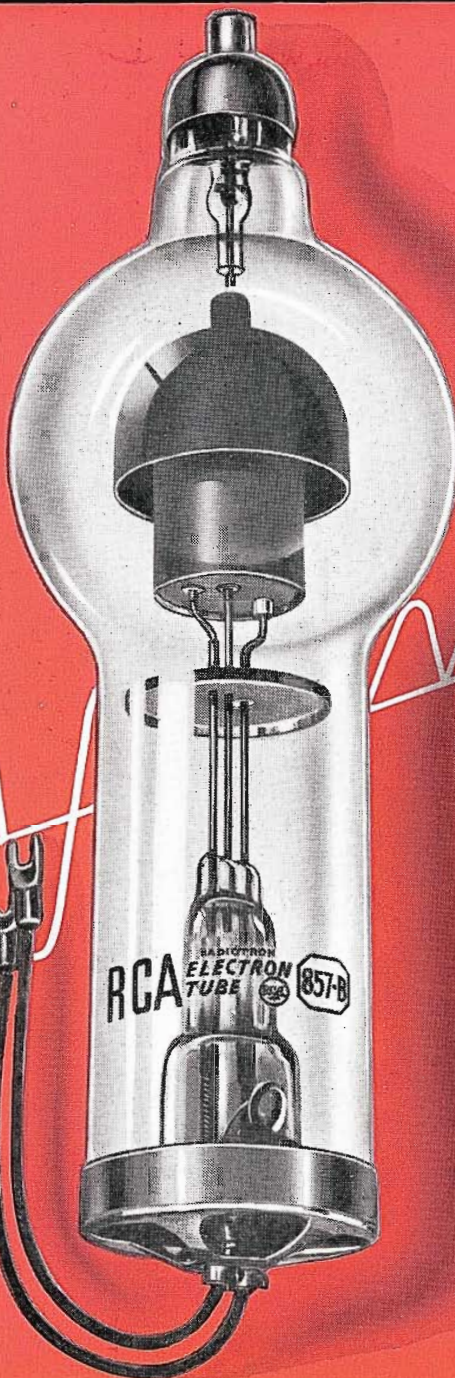

RCA-857B
High Power,
Mercury-Vapor
Rectifier

**... and
still
going
strong!***

**Reported July 8, 1955*

The Canadian Broadcasting Corporation writes:

"In the RCA 50-kw shortwave transmitter at the Canadian Broadcasting Corporation's International Service transmitting station at Sackville, New Brunswick, one RCA-857B mercury-vapor rectifier tube has been operating for 33,738 hours—and another for 30,571 hours."

RCA-857B is just ONE type among the many RCA rectifiers that are setting year-after-year records for maximum performance—in greater operating reliability of equipment—minimum equipment outages—lower capital investment per hour of tube operation!

Your local RCA Tube Distributor is ready to meet your requirements on RCA Tubes of all types for broadcast station operations—regardless of whether your station is AM, FM, television, or international. For prompt attention—call him!

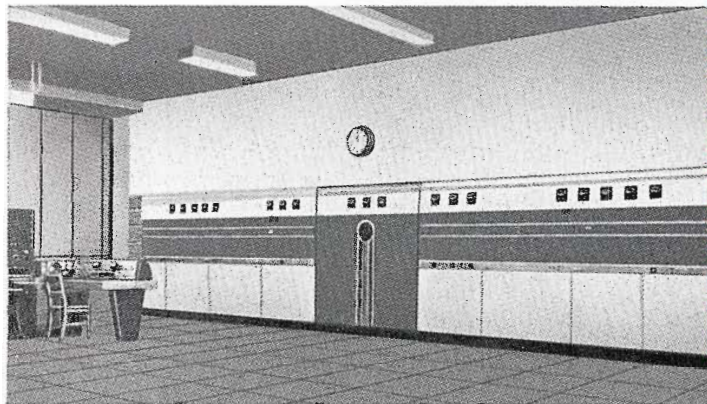

RCA 50-KW Shortwave Transmitter using RCA-857B high-power mercury-vapor rectifiers



RADIO CORPORATION of AMERICA
ELECTRON TUBES

HARRISON, N.J.

ALL THE ACTION! ALL THE COLOR! FIRST TIME EVER!
NCAA COLLEGE FOOTBALL GAMES ON COLOR TV!



Notre Dame vs. Michigan State, Oct. 15 on NBC-TV. Other games, Oct. 29 and Nov. 26.

BIG COLOR BY RCA VICTOR

Big Color is here—21-inch RCA Victor Color TV—just in time for college football!

The riot of school colors in the stands . . . the glitter of brass bands . . . and on the green turf, action! College football—in Big Color by RCA Victor!

See an NBC-TV football colorcast at your RCA Victor dealer's—free. See how much Big Color adds to TV enjoyment. After the game, see how the same set receives all your favorite black-and-white programs in black-and-white, too. For this is "Compatible Color," pioneered and developed by RCA.

Don't fail to see the games in Big Color by RCA Victor—at your dealer's or in your own home!

Worry-Free! With an RCA Victor Factory Service Contract (optional, extra) you get expert installation and maintenance. Available in most TV areas but only to RCA Victor TV owners.

Manufacturer's nationally advertised UHF-VHF list prices shown, subject to change.

See Milton Berle, Martha Raye alternately 2 out of every 3 Tuesdays, NBC-TV. Don't miss "Producers' Showcase" in RCA Compatible Color or black-and-white, NBC-TV, Monday, October 17.



FIRST IN BLACK-AND-WHITE TELEVISION

RCA VICTOR
TRADE MARK RADIO CORPORATION OF AMERICA

FIRST IN COMPATIBLE COLOR TELEVISION



New Director 21 in mahogany or blond tropical hardwood finish (21CT662) \$895. Not shown: **The Seville 21** Console (21CT661), \$795.